

# specifications

## RF7.PPS.3.SD

### ReFlex Series, 3 Door (Solid), Medium Salad Preparation Fridge

Project: \_\_\_\_\_

Item No: \_\_\_\_\_

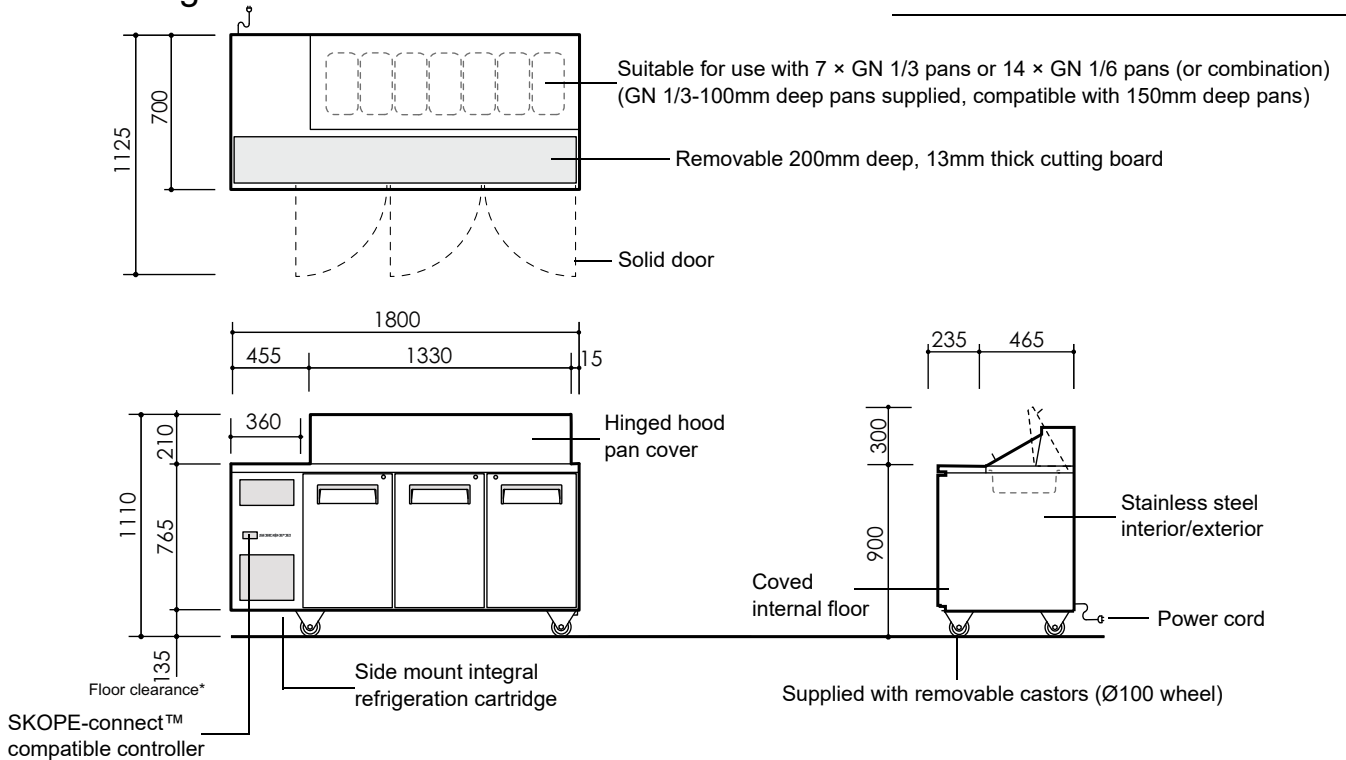

CABINET	
Doors	3 × self-closing, lockable, solid swing doors with stay-open position at over 90°, hinged LH, LH, RH
Internal door opening	3 × door openings: 590mm high × 370mm wide
Shelves	6 × adjustable height shelves. Middle shelves: 475mm wide × 510mm deep. Outer shelves: 415mm wide × 510mm deep. Each shelf is held in place with 4 × shelf clips. Additional shelf clips are available on request.
Worktop	Removable, food grade, 13mm plastic cutting board
Material	304 AISI stainless steel interior and exterior
PERFORMANCE	
Max. ambient temperature	40°C (lid(s) closed), or 30°C (lid(s) open)
Temperature range	1°C to 5°C (adjustable with SKOPE-connect™ -2°C to 15°C)
Total energy consumption	3.58 kWh/24h (@ 30°C/55% relative humidity)
Annual running cost	\$392 p.a. (@ \$0.30/kWh)
ELECTRICAL	
Electrical safety climate class	5 (40°C/40% relative humidity)
Interior lighting	2 × 400mm, 4W LED lights (door activated)
Power cord	2.7m, 10 Amp plug and lead
Power supply	220-240 Volts a.c. 50 Hz, single phase supply
Current draw	2.0 Amps (includes unit 1.0 Amps)
REFRIGERATION	
Controller	SCS Connect (SKOPE-connect™ compatible)
Connectivity interface	Bluetooth® wireless technology
Refrigeration system	Side-mounted, integral, removable refrigeration cartridge (part number ULQCN1-0029)
Refrigerant	R290 / 90g (natural refrigerant)
Nominal capacity	600 Watts
Heat rejection (Avg./peak)	150 Watts/160 Watts
Drainage	No plumbing required

DIMENSIONS		
	External	Internal
Height	1110mm	490mm
Width	1800mm	1350mm
Depth	700mm	540mm
Floor area	1.26m <sup>2</sup>	
Weight	162kg	
Gross volume	357L	

Height variation	
Supplied castors	1110mm
Supplied height adjustable legs	n.a.
No castors	975mm

Dimensional tolerances		
Before installing this cabinet allow the following dimensional tolerances:		
Linear dimensions	Overall cabinet dimensions	
Less than 1 metre	±5mm	
More than 1 metre	-5mm to +10mm	
	Length of multiple cabinets	
	At each joint	At each end wall
Less than 1 metre	±5mm	+15mm
More than 1 metre	-5mm to +10mm	+15mm

Ventilation requirements	
Top	Not required
Sides	Not required
Back	Not required
Bottom	Not required