

Fv 913

Countertop freezer with dynamic cooling



LIEBHERR

Fv 913

Countertop freezer



Gross/net capacity	93/66 litre
Ext. dimensions in mm (w/d/h)	497/558/816
Int. dimensions in mm (w/d/h)	377/391/609
Energy consumption in 365 days	1007 kWh
Ambient temperature range	+10°C to +32°C ¹
Refrigerant	R 290
Connection Rating	1.5 A
Voltage	220-240 V~
Cooling system	
Defrosting	automatic
Temperature range	-10°C to -25°C
Housing material/colour	steel/grey
Door material	Insulated glazed door
Liner Material	steel
Type of Control	electronic controller
Temperature display	external digital
Interior light	LED
Fault: warning signal	visual and audible
Adjustable Shelving	2
Feet	Steel, zined
Lock	fitted
Self-closing door	yes
Door hinges	Right/reversible
Insulation	
Gross/net weight	48.9/46.4kg
EAN-Nr.	955000034600

Features



Environmentally friendly refrigerants

Liebherr appliances are optimised for maximum energy efficiency and low operating costs. We only use the natural and environmentally-friendly refrigerants R 600a and R 290. When used with highly efficient compressors, these are extraordinarily efficient and, with their low global warming potential, also future-proof.



Efficient refrigeration system

Liebherr guarantees the outstanding quality of its refrigeration systems through expertise derived from decades of experience in the refrigeration technology sector, and through continuous research and development. By employing only premium-quality compressors, condensers, evaporators and other refrigeration components the energy consumption and operating costs of Liebherr appliances are significantly reduced.



NoFrost technology

No need to defrost: Liebherr's NoFrost technology provides outstanding freezing performance for professional-standard, long-term freshness. To ensure that the freezer always remains ice-free and that food does not frost over, food is frozen using circulating chilled air and any moisture is removed.

High impact product presentation

The energy-saving LED interior lighting provides the ideal presentation of the products stored. When combined with an "Action Area Rack" you can increase your sales volume on the spot by 60%, when combined with an EFE/EFI chest freezer

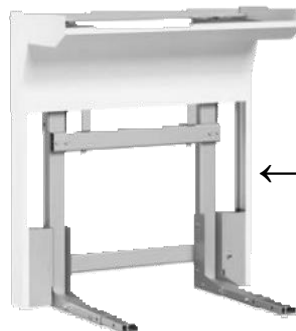

Technical drawing

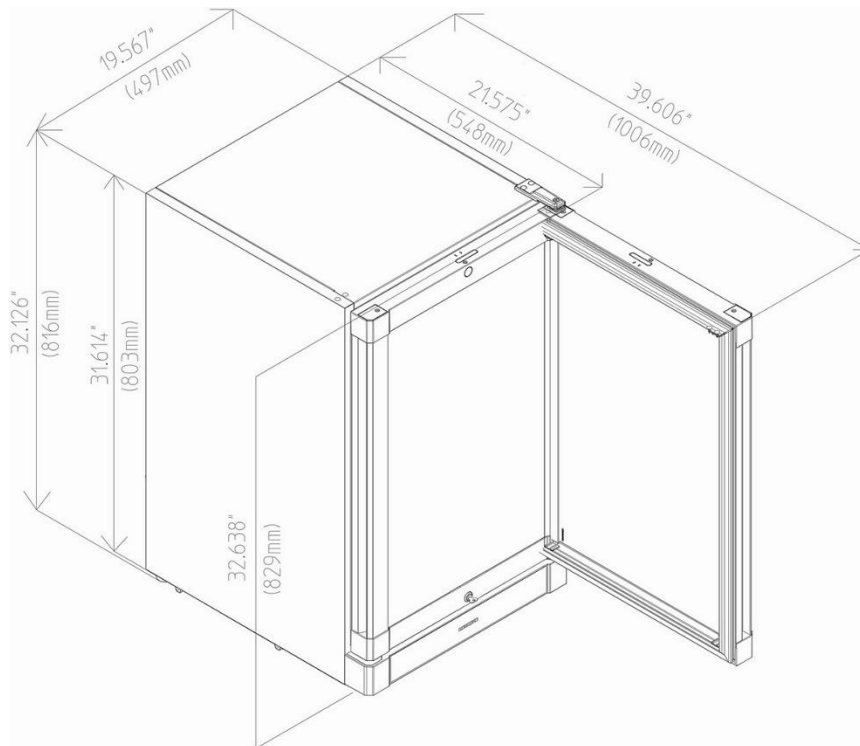

Products and their details are staged for advertising purposes. Whilst every effort is made to ensure all specifications and information in this flyer are accurate, Liebherr reserves the right to make changes without notification. Where actual appliance measurements, specifications, and ratings are crucial, we recommend that the actual appliance installation instructions that accompany each appliance be checked. Liebherr will not be liable for any damage. (29.11.2023)

