

Waldorf[®] 800 SERIES

Installation and Operation Manual

Gas Pasta Cooker

PC8140G

PCL8140G



Date Purchased

Serial Number

Dealer

Service Provider



For use in GB & IE

230008-12

MANUFACTURED BY

Moffat Limited

Christchurch
New Zealand

INTERNATIONAL CONTACTS

AUSTRALIA

Moffat Pty Limited

E.Mail: vsales@moffat.com.au
Main Office: (tel): +61 (03) 9518 3888
(fax): +61 (03) 9518 3833
Service: (tel): 1800 622 216
Spares: (tel): 1800 337 963
Customer Service: (tel): 1800 335 315
(fax): 1800 350 281

CANADA

Serve Canada

Web: www.servecanada.com
E.Mail: info@servecanada.com
Sales: (tel): 800 551 8795 (Toll Free)
Service: (tel): 800 263 1455 (Toll Free)

NEW ZEALAND

Moffat Limited

Web: www.moffat.co.nz
E.Mail: sales@moffat.co.nz
Main Office: (tel): 0800 663328

UNITED KINGDOM

Blue Seal

Web: www.blue-seal.co.uk
E.Mail: sales@blue-seal.co.uk
Sales: (tel): +44 121 327 5575
(fax): +44 121 327 9711
Spares: (tel): +44 121 322 6640
(fax): +44 121 327 9201
Service: (tel): +44 121 322 6644
(fax): +44 121 327 6257

UNITED STATES

Moffat

Web: www.moffat.com
Sales: (tel): 800 551 8795 (Toll Free)
(tel): +1 336 661 1556
(fax): +1 336 661 9546
Service: (tel): 800 858 4477 (Toll Free)
(tel): +1 366 661 1556
(fax): +1 336 661 1660

REST OF WORLD

Moffat Limited

Web: www.moffat.co.nz
E.Mail: export@moffat.co.nz

The reproduction or copying of any part of this manual by any means whatsoever is strictly forbidden unless authorized previously in writing by the manufacturer.

In line with policy to continually develop and improve its products, Moffat Ltd. reserves the right to change the specifications and design without prior notice.

PC(L)8140G GAS PASTA COOKER (Single Tank - 40 Ltr)

Introduction	2
Specifications	3
Model Numbers Covered in this Specification	
General	
Optional Accessories	
Gas Supply Requirements	
Gas Connection	
Water Supply Requirements	
Dimensions	5
Installation	6
Installation Requirements	
Unpacking	
Location	
Clearances	
Assembly	
Gas Connection	
Water Connection	
Drainage Connection	
Commissioning	
Operation	10
Operation Guide	
Description of Controls	
Before Use	
Filling the Tank	
Lighting Pilot Burner	
Lighting Main Burner	
Turning 'OFF' the Pasta Cooker	
Cleaning and Maintenance	13
General	
Draining and Cleaning	
After Each Use	
Daily Cleaning	
Weekly Cleaning	
Periodic Maintenance	
Fault Finding	16
Wiring Schematic	17
Gas Conversion and Specifications	18
Conversion Procedure	
Gas Specifications	
Replacement Parts List	21

Introduction

We are confident that you will be delighted with your WALDORF GAS PASTA COOKER and it will become a most valued appliance in your commercial kitchen.

To ensure you receive the utmost benefit from your new Waldorf appliance, there are two important things you can do.

Firstly:

Please read the instruction book carefully and follow directions given. The time taken will be well spent.

Secondly:

If you are unsure of any aspect of the installation, instructions or performance of your appliance, contact your WALDORF dealer promptly. In many cases a phone call could answer your question.

CE Only:

These instructions are only valid if the country code appears on the appliance. If the code does not appear on appliance, refer to supplier of this appliance to obtain technical instructions for adapting appliance to conditions for use in that country.



Warning

IMPROPER INSTALLATION, ADJUSTMENT, ALTERATION, SERVICE OR MAINTENANCE CAN CAUSE PROPERTY DAMAGE, INJURY OR DEATH. READ THE INSTALLATION, OPERATING AND MAINTENANCE INSTRUCTIONS THOROUGHLY BEFORE INSTALLING OR SERVICING THIS APPLIANCE.



Warning

INSTRUCTIONS TO BE FOLLOWED IN THE EVENT THE USER SMELLS GAS ARE TO BE POSTED IN A PROMINENT LOCATION. THIS INFORMATION SHALL BE OBTAINED BY CONSULTING THE LOCAL GAS SUPPLIER.



Warning

GREAT CARE MUST BE TAKEN BY THE OPERATOR TO USE THE EQUIPMENT SAFELY TO GUARD IT AGAINST RISK OF FIRE.

- **THE APPLIANCE MUST NOT BE LEFT ON UNATTENDED.**
- **IT IS RECOMMENDED THAT A REGULAR INSPECTION IS MADE BY A COMPETENT SERVICE PERSON TO ENSURE CORRECT AND SAFE OPERATION OF YOUR APPLIANCE IS MAINTAINED.**
- **DO NOT STORE OR USE GASOLINE OR OTHER FLAMMABLE VAPOURS OR LIQUIDS IN THE VICINITY OF THIS OR ANY OTHER APPLIANCE.**
- **DO NOT SPRAY AEROSOLS IN THE VICINITY OF THIS APPLIANCE WHILE IT IS IN OPERATION.**



Caution

- **This appliance is for professional use and is only to be used by qualified persons.**
- **Only authorised service persons are to carry out installation, servicing or gas conversion operations.**
- **Components having adjustments protected (e.g. paint sealed) by the manufacturer should not be adjusted by the user / operator.**
- **DO NOT operate the appliance without the legs supplied fitted.**

Model Numbers Covered in this Specification

PC[1]8140G GAS PASTA COOKER (Single Tank - 40 Ltr)

NOTE:

- [1]: - Back Options;
- - Standard Models.
 - L - Low Back Models.

General

A commercial heavy duty, gas fired high performance Pasta Cooker designed for pasta cooking commercial high production output, using LPG (Propane) or Natural Gas. The boiling medium is contained within a heavy gauge stainless steel tank, heated by one infra red surface burner from beneath the tank.

This Pasta Cooker features an Over Temperature Safety Cut Out System with Full Flame Failure Safety Controls.

An open tank design to make cleaning a simple and easy task.

Optional Accessories

This appliance can be fitted with the following optional accessories, (refer to the 'Replacement Parts List' for details).

- Plinth Kit.

Gas Supply Requirements

- Australia New Zealand Only:

	Natural Gas	LP Gas / (Propane)
Input Rating	46 MJ/hr	47 MJ/hr
(N.H.G.C.)	(44,547 Btu/hr)	(44,547 Btu/hr)
Supply Pressure	1.13 - 3.40 kPa (4.5" - 13.5" w.c.)	2.75 - 4.50 kPa (11" - 18.0" w.c.)
Burner Operating Pressure	0.92 kPa (*) (3.7" w.c.)	2.6 kPa (*) (10.2" w.c.)
Gas Connection	$\frac{3}{4}$ " BSP Male	

- UK Only:

Appliance Classification

Category: II_{2H3P}.

Flue Type: A₁.

	Natural Gas (G20)		Propane (G31)	
	Nominal	Reduced	Nominal	Reduced
Heat Input (nett)	12.0 kW	5.4 kW	12.5 kW	6.2 kW
Gas Rate	1.27 m ³ /hr	0.42 m ³ /hr	0.97 kg/hr	0.48 kg/hr
Supply Pressure	20 mbar		37 mbar	
Burner Operating Pressure	9.5 mbar (*)		27.7 mbar (*)	
Gas Connection	$\frac{3}{4}$ " BSP Male			

NOTE: (*) Measure burner operating pressure at upper test point (Supply Pressure) on gas control valve located behind control panel, this is to be carried out with burner operating at 'High Flame' setting. Refer to 'Gas Conversion and Specification' Section for further details.

Specifications

Gas Connection

Gas supply connection point is located 152mm from left hand side, 36mm from rear of appliance, 124mm from floor and is entered from beneath appliance. An optional rear connection is available.

Connection is $\frac{3}{4}$ " BSP male.

Water Supply Requirements

A cold water supply must be connected to water inlet connection (R $\frac{1}{2}$ " BSP), located 50mm from LH side, 556mm from rear and 151mm from floor. Water connection should be plumbed in, in accordance with National / Local Codes covering installation.

Maximum water supply pressure 550 kPa (80psi).

Tank max capacity - 40ltrs of water.

PC(L)8140G

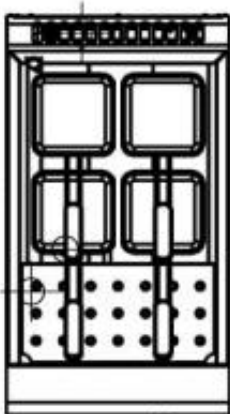
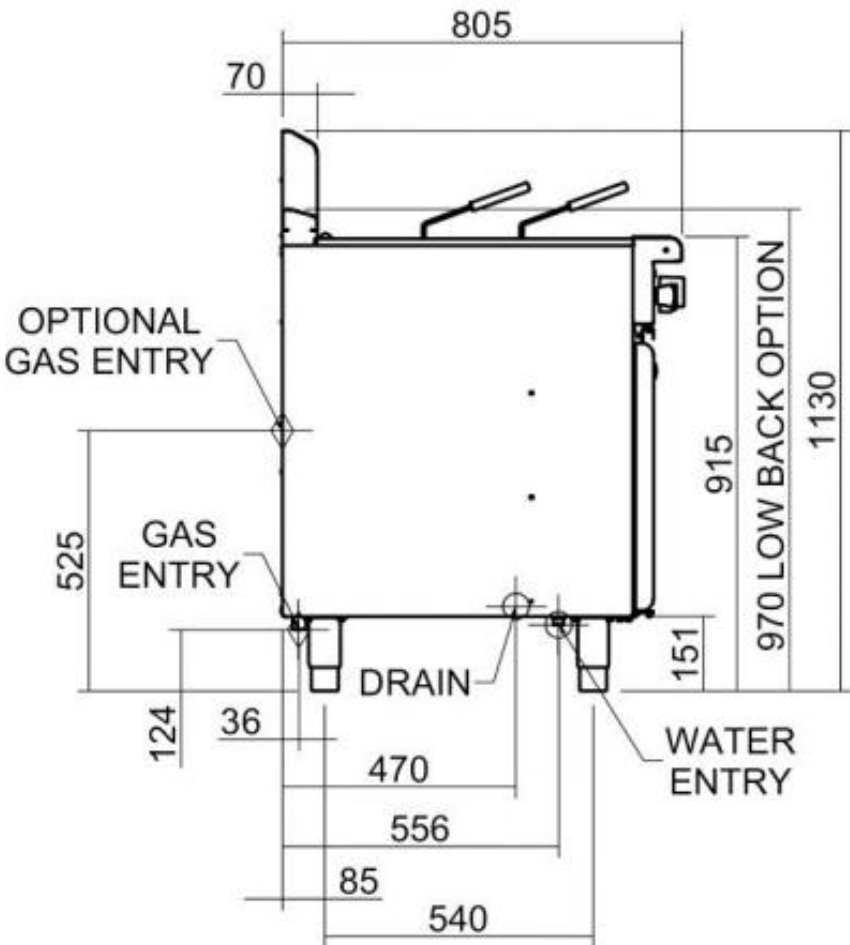
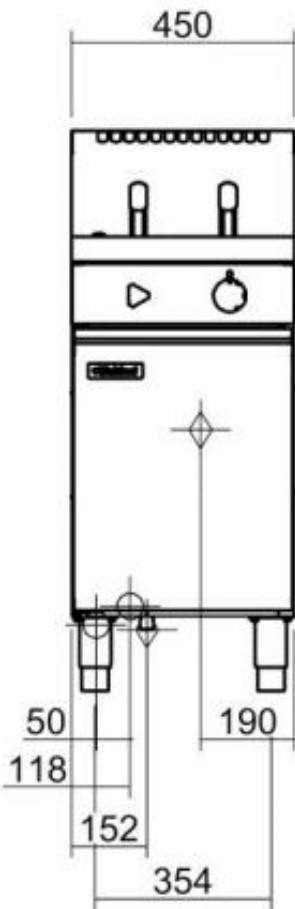

Installation

Installation Requirements

NOTE:

- It is most important that this appliance is installed correctly and that operation is correct before use. Installation shall comply with local, gas, health and safety requirements.
- This appliance shall be installed with sufficient ventilation to prevent occurrence of unacceptable concentrations of health harmful substances in the room, the appliance is installed in.

Waldorf pasta cookers are designed to provide years of satisfactory service and correct installation is essential to achieve the best performance, efficiency and trouble-free operation.

This appliance must be installed in accordance with National installation codes and in addition, in accordance with relevant National / Local codes covering gas and fire safety.

Australia:	- AS5601	- Gas Installations.
New Zealand:	- NZS5261	- Gas Installation.
Australia / New Zealand	- AUS /NZS3500	- Plumbing & Drainage.
United Kingdom:	- Gas Safety (Installation & Use) Regulations 1998.	
	- BS6173	- Installation of Catering Appliances.
	- BS5440	- Parts 1 & 2 Installation Flueing & Ventilation.
Ireland:	- IS 820	- Non Domestic Gas Installations.

Installations must be carried out by qualified service persons only. Failure to install equipment to the relevant codes and manufacturer's specifications shown in this section will void the warranty.

Components having adjustments protected (e.g. paint sealed) by the manufacturer, are only to be adjusted by an authorised service agent. They are not to be adjusted by the installation person.

Unpacking

- Remove all packaging and transit protection from appliance including all protective plastic coating from door outer panel and exterior stainless steel panels.
- Check equipment and parts for damage. Report any damage immediately to the carrier and distributor.
- Report any deficiencies to distributor who supplied the appliance.
- Check available gas supply is correct to as shown on rating plate located on inside of access door.
- Check the following parts have been supplied with the appliance:

	FN8140G
Baskets	4
Basket Trays	1

Location

1. This appliance must be installed in a suitably ventilated room to prevent dangerous build up of combustion products.
2. Installation must allow for a sufficient flow of fresh air for combustion air supply.

Combustion Air Requirements

PC8140G	
Natural Gas (G20)	13 m ³ /hr
LPG / Propane (G31)	13 m ³ /hr

3. Position appliance in its approximate working position.

4. All air for burner combustion is supplied from beneath appliance. Legs must always be fitted and no obstructions placed beneath or around base of appliance, as obstructions will cause incorrect operation and / or failure of appliance.
5. Components having adjustments protected (e.g. paint sealed) by manufacturer are only to be adjusted by an authorised service agent. They are not to be adjusted by the installation person.

NOTE: Do not obstruct or block appliances flue. Never directly connect a ventilation system to appliance flue outlet.

Clearances

NOTE:

- Only non-combustible materials can be used in close proximity to this appliance.
- In order to facilitate easy operation, drainage and servicing of appliance, a minimum of 600mm clearance should be maintained at front of appliance.

Any gas burning appliance requires adequate clearance and ventilation for optimum and trouble-free operation. The following minimum installation clearances are to be adhered to:

	Combustible Surface	Non Combustible Surface
Left / Right hand side	50mm	0mm
Rear	50mm	0mm

Assembly

This model is delivered completely assembled. Ensure that the adjustable feet are securely attached.

NOTE:

- This appliance is fitted with adjustable feet to enable appliance to be positioned securely and level. This should be carried out on completion of gas connection. Refer to 'Gas Connection' section overleaf.

Optional Accessories (Refer to Replacement Parts List)

- Plinth Kit. For installation details, refer to instructions supplied with each kit.

Installation

Gas Connection

NOTE: ALL GAS FITTING MUST ONLY BE CARRIED OUT BY A QUALIFIED SERVICE PERSON.

1. Waldorf Pasta Cookers do not require an electrical connection, they function totally on gas supply only.
2. It is essential that gas supply is correct for appliance to be installed and that adequate supply pressure and volume are available. The following checks should be made before installation:-
 - a. **Gas Type** the appliance has been supplied for is shown on coloured stickers located above gas entry point and on rating plate. Check that this is correct for gas supply appliance is being installed for. Gas conversion procedure is detailed in this manual.
 - b. **Supply Pressure** required for this appliance is shown in 'Specifications' section of this manual. Check gas supply to ensure adequate supply pressure exists.
 - c. **Input Rate** of this appliance is also shown on Rating Plate fitted to inside of access door and in 'Specifications' section of this manual. Input rate should be checked against available gas supply line capacity. **Particular note should be taken if appliance is being added to an existing installation.**

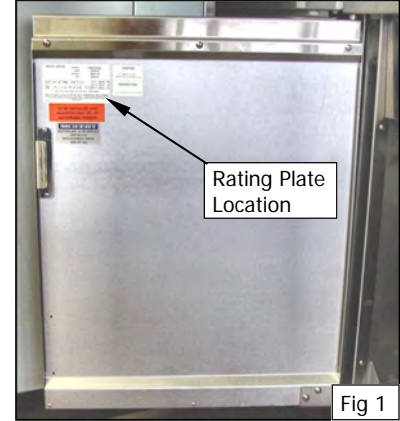

NOTE: It is important that adequately sized piping runs directly to connection joint on appliance, with as few tees and elbows as possible to give maximum supply volume.

3. Fit gas regulator supplied, into gas supply line as close to appliance as possible.

NOTE: Gas pressure regulator provided with this appliance is convertible between Natural Gas and LPG as shown in 'Gas Conversion Section' in this manual. Ensure regulator is converted to correct gas type that appliance will operate on. Regulator outlet pressure is fixed ex-factory for gas type that regulator is converted to and it is NOT to be adjusted.

Regulator connections are $\frac{3}{4}$ " BSP female.
Connection to appliance is $\frac{3}{4}$ " BSP male.

(Refer to 'Specifications' section for gas supply location dimensions).

NOTE: A Manual Isolation Valve must be fitted to individual appliance supply line.

4. Correctly locate appliance into its final operating position and using a spirit level, adjust legs so that unit is level and at correct height.
5. Connect gas supply to appliance.
6. Check gas operating pressure is as shown in 'Specifications' section. If pressure is incorrect, adjust pressure by adjusting regulator screw of gas control valve as shown in 'Gas Conversion and Specifications' section.
7. Check all gas connections for leakages using soapy water or other gas detecting equipment.



Warning

DO NOT USE A NAKED FLAME TO CHECK FOR GAS LEAKAGES.

NOTE: Measure operating pressure at Burner Operating Pressure test point on gas control valve, this is to be carried out with burner operating at 'High Flame' setting. Operating pressure is ex-factory set, through appliance regulator and not to be adjusted, apart from when carrying out gas conversion, if required. Refer to 'Gas Conversion and Specification' Section for further details.

8. Turn 'OFF' mains gas supply and bleed gas out of appliance gas lines.
9. Turn 'ON' gas supply and appliance.
10. Verify operating pressure remains correct
11. Check pilot flame size. (Re-adjust if required by changing pilot injector. Refer to Gas Conversion Section).

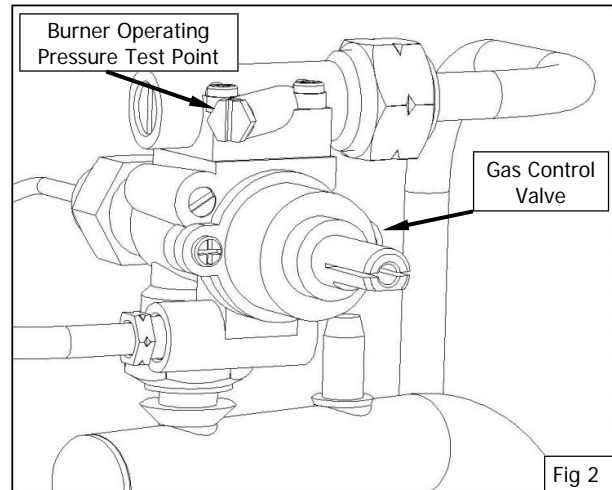

Water Connection

NOTE: The water connection shall be installed in accordance with local water regulations in force and the applicable standard / code, e.g. EN 1717 in UK / Ireland, PCA in Australia.

A cold water supply must be connected to the water inlet connection (R¹/₂" BSP), located 50mm from LH side, 556mm from rear and 151mm from floor.

Water inlet pressure must be as follows:-

- Minimum water supply pressure 150kPa (22psi).
- Maximum water supply pressure 550kPa (80psi).

Drainage Connection

- Water is drained from appliance through a valve located behind the front control panel.
- A waste water tundish must be fitted below appliance drain outlet. This should be a minimum of 127mm (5") major diameter.
- If required, drain outlet can be extended to exit above tundish. All drain piping must be with materials suitable for conveying boiling water.
- Drain connection is R1" BSP drain / overflow.

Commissioning

The following commissioning checks must be carried out before pasta cooker is handed over for use, to ensure that unit operates correctly and operator(s) understand correct operating procedure.

1. Before leaving the new installation;
 - a. Check the following functions in accordance with operating instructions specified in 'Operation' section of this manual.
 - Light Pilot Burner.
 - Light Main Burner.
 - b. Ensure each operator has been instructed in areas of correct lighting, operation, and shutdown procedures for appliance.
2. This manual must be kept by the owner for future reference and a record of ***Date of Purchase, Date of Installation*** and ***Serial Number of Unit*** recorded and kept with this manual. **(These details can be found on Rating Plate attached to inner R/H side of front access door panel. Refer to Figure 1 in 'Installation' section).**

NOTE: If for some reason it is not possible to get appliance to operate correctly, shut 'Off' gas supply and contact supplier of this unit.

Operation

Operation Guide

 **Caution**

- This appliance is for professional use and is only to be used by qualified persons.
- Only authorised service persons are to carry out installation, servicing or gas conversion operations.
- Components having adjustments protected (e.g. paint sealed) by the manufacturer should not be adjusted by the user / operator.

1. WALDORF 'Pasta Cookers have been designed to provide simplicity of operation and 100% safety protection.

 **Warning**

NEVER OPERATE APPLIANCE WITH GAS CONTROL VALVE BETWEEN 'HIGH' FLAME AND 'PILOT' POSITION.

2. Improper operation is almost impossible, however bad operation practices can produce a poor quality product. To use this pasta cooker correctly please read the following sections carefully;
 - Filling the Tank with Water.
 - Lighting the Pilot Burner.
 - Lighting the Main Burner.
 - Draining and Cleaning.

Description of Controls

- A commercial heavy duty, gas fired pasta cooker using an infra red burner system.
- Available in single model type.
- This model is fitted with single main burner and pilot burner and is controlled by a single gas controller with flame failure protection to control both main burner and pilot.
- Open tank design to simplify cleaning operation.

PC8140G Pasta Cooker Controls

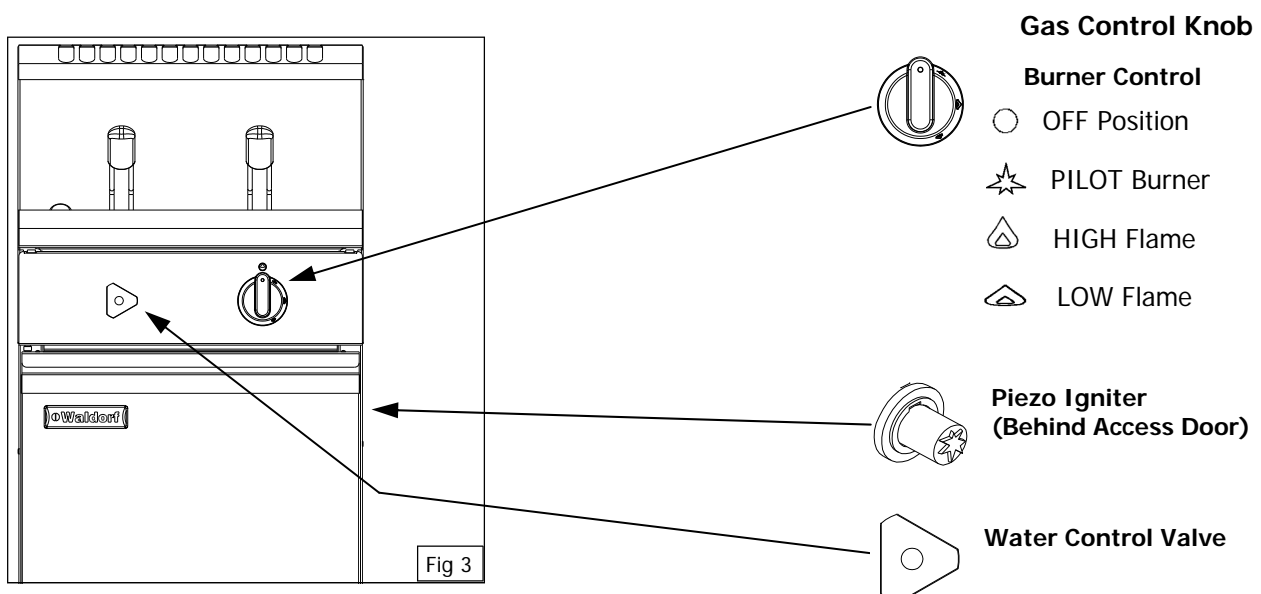

Before Use



Warning

GREAT CARE MUST BE TAKEN BY OPERATOR, TO USE THE PASTA COOKER SAFELY, TO GUARD AGAINST RISK OF INJURY AND FIRE.

- **DO NOT LEAVE PASTA COOKER UNATTENDED DURING OPERATION.**
- **DO NOT OVER FILL WATER IN PASTA COOKER ABOVE UPPER FILL LEVEL MARK.**
- **DO NOT ALLOW WATER IN PASTA COOKER TO FALL BELOW LOWER LEVEL MARK.**
- **DO NOT USE FLAMMIBLE SOLVENTS AND CLEANING AIDS ON OR IN CLOSE PROXIMITY TO PASTA COOKER WHILST PASTA COOKER IS STILL HOT.**

1. Check gas supply is turned 'On'.
2. Check that no foreign articles are in the tank.

Filling the Tank



Warning

**DANGER OF FIRE EXISTS IF WATER LEVEL IS BELOW MINIMUM 'LOW' INDICATED LEVEL.
NEVER OPERATE THE APPLIANCE EMPTY.**

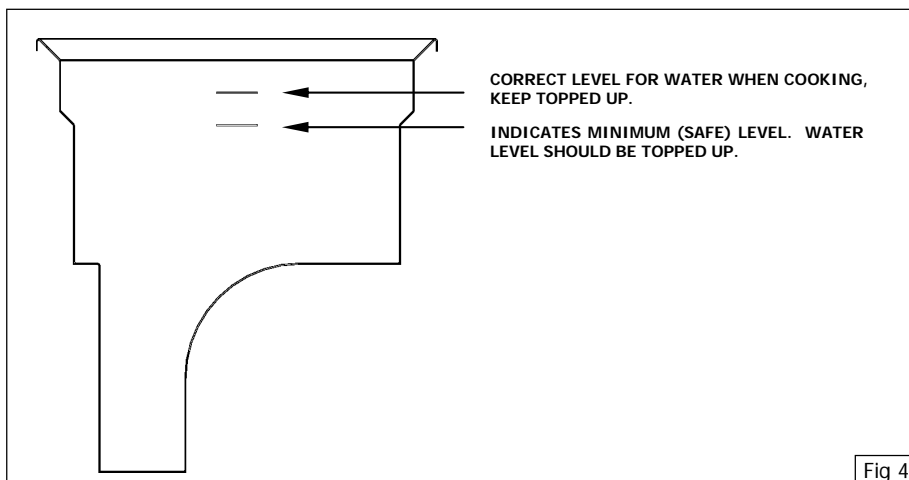

NOTE: Tank capacity - 40 Ltrs of water.

1. Before filling tank, always check drain valve behind door is closed. A locking slide is provided on valve and this should always be locked in position during use.
2. Turn water supply 'ON'. Open appliance water valve and fill tank with water.
3. Water level will remain at a constant height as there is an overflow at front of tank.
4. During cooking, water level will reduce as it evaporates as steam when boiling and when it overflows as loaded baskets are dropped into tank.
5. To maintain correct water level, water tap should be adjusted to give a water flow out of water supply nozzle that just causes water to continually flow out of overflow.

This method provides:

- Maintained water level for cooking.
- Skimming or flushing effect to prevent cooking water becoming gummed up with pasta residue.

Operation

Lighting Pilot Burner



Caution

Do NOT ignite burner if tank is empty (No Water). Ensure tank is filled to correct level before igniting main burner.

1. With pasta cooker tank full of water, pilot burner can be lit.
2. Check gas supply is turned 'On' at mains supply.
3. Depress and rotate gas control knob to 'PILOT' position and hold knob depressed.
4. Open front access door and depress piezo igniter located on bulkhead panel, until pilot burner ignites.
5. Continue holding gas control knob depressed for approx. 10 to 15 seconds after igniting pilot burner, then release, pilot burner should remain alight.
6. Ensure pilot burner is alight, by checking that pilot flame is alight with access door open.
7. If pilot burner does not ignite, repeat Items 1 to 6 above.

Lighting Main Burner

1. Depress and rotate gas control knob to 'High Flame' position, main burner will ignite automatically off pilot burner.
2. Gas control knob can be regulated between 'High Flame' and 'Low Flame' position to regulate cooking temperature.
3. It will take approximately 30 minutes to heat water in tank from 20°C to 100°C.

Turning 'Off' the Pasta Cooker

To the 'Pilot' Position

- a. Depress and rotate gas control valve clockwise to 'Pilot' position.
- b. Main burner will extinguish and 'Pilot' will remain alight.

To the 'Off' Position

- a. Depress and rotate gas control valve fully clockwise to 'Off' position.
- b. 'Pilot' burner will extinguish.

IMPORTANT:

Should any abnormal operation like;

- ignition problems,
 - abnormal burner flame,
 - burner control problems,
 - partial or full loss of burner flame in normal operation, be noticed, appliance requires IMMEDIATE service by a qualified service person and should not be used until such service is carried out.
-

General



Warning

DO NOT USE FLAMMIBLE SOLVENTS AND CLEANING AIDS ON OR IN CLOSE PROXIMITY OF PASTA COOKER WHILST COOKER IS STILL HOT.



Caution

Always turn 'Off' gas supply before cleaning.

This appliance is not water proof.

Do not use water jet spray to clean interior or exterior of this appliance.

Clean pasta cooker regularly. A clean pasta cooker looks better, will last longer and will perform better. A dirty pasta cooker will hinder transfer of heat from cooking surface to food. This will result in loss of cooking efficiency.



Caution

If cleaning detergents enter inner parts of appliance, rusting will occur on pipe work, installation elements, heating elements, gas fittings and electrical components, this will cause premature failure of appliance.

NOTE:

- **DO NOT clean appliance using high pressure water or steam jets.**
- **DO NOT pour water directly over appliance.**
- **DO NOT use wire brushes. Clean pan regularly after each use.**
- **DO NOT use combustible liquids to clean appliance.**
- **DO NOT use harsh abrasive detergents, sharp scrapers, strong solvents or caustic detergents as they will damage appliance.**
- **DO NOT use any chloric or bleaching detergents to clean appliance.**
- **Ensure that any detergent or cleaning material has been completely removed after each cleaning.**
- **DO NOT use saline or sulphuric acid preparations for descaling appliance.**
- **Ensure protective gloves are worn during cleaning.**
- **Clean pan regularly after each use.**

Draining and Cleaning

Opening the Drain Valve

- a. Lift locking slide on valve handle (Fig 5) to release the valve.
- b. While holding locking slide in the withdrawn position, rotate handle anticlockwise (Fig 6) to open valve.
- c. When valve is closed, slide locking slide down over locking valve, as shown in Fig.5, to prevent accidental opening the valve.

Cleaning and Maintenance

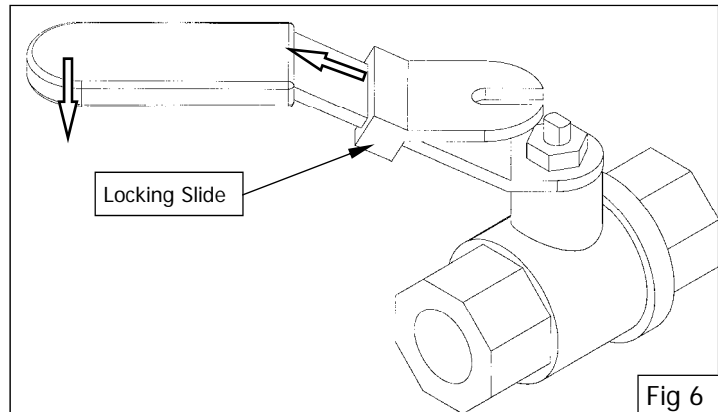
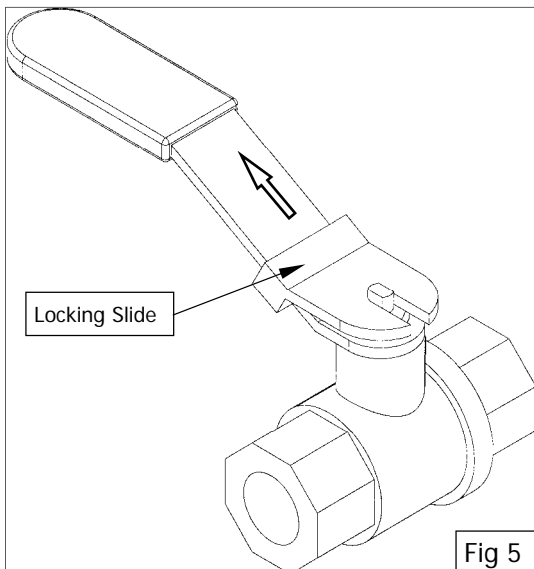

After Each Use



Warning

HOT WATER WILL SCALD - DO NOT RUSH THIS JOB.

1. Clean interior of pan regularly after each use. Do not use wire brushes on pan. Clean using a mild detergent and a hot water solution using soft cloth or a soft bristled brush. Dry appliance thoroughly using a dry clean cloth.

Daily Cleaning



Warning

DO NOT ATTEMPT TO MOVE PASTA COOKER WHILST COOKER IS FULL OF WATER.

BEFORE ATTEMPTING TO MOVE PASTA COOKER, ENSURE THAT ALL WATER HAS BEEN DRAINED FROM TANK. REFER TO INFORMATION ON PREVIOUS PAGE ON HOW TO DRAIN WATER FROM PASTA COOKER.

1. Water should be drained and re-filled regularly. Open drain valve slowly to minimise splashing. Waste water will drain into tundish fitted below appliance drain outlet.
2. When tank is empty, open drain valve fully and check for any particles or residue lodged in valve. Clean out valve with a stiff nylon brush. Do not use a wire brush or metal rods as these damage valve seat and will eventually lead to valve leakage.
3. If obstruction in valve cannot be removed with a brush, use a wooden probe to dislodge obstruction.
4. Clean interior and exterior of pan regularly at end of each day. Do not use wire brushes on pan. Clean using a mild detergent and a hot water solution using soft cloth or a soft bristled brush. Dry appliance thoroughly using a dry clean cloth.
5. Once daily cleaning operation is completed, ensure that drain valve has been closed.
6. At end of each day or at end of each shift, clean exterior of pasta cooker using a mild detergent and a hot water solution using soft cloth or a soft bristled brush.

Weekly Cleaning



Warning

DO NOT ATTEMPT TO MOVE PASTA COOKER WHILST COOKER IS FULL OF WATER.

BEFORE ATTEMPTING TO MOVE PASTA COOKER, ENSURE THAT ALL WATER HAS BEEN DRAINED FROM TANK. REFER TO INFORMATION ON PREVIOUS PAGE ON HOW TO DRAIN WATER FROM PASTA COOKER.

NOTE:

- If pasta cooker usage is very high, we recommend that weekly cleaning procedure is carried out more frequently.
- Ensure that protective gloves are worn during cleaning.
- **DO NOT use harsh abrasive detergents, strong solvents, sharp scrapers or caustic detergents as they will damage surface of pasta cooker.**
- Ensure that water circuit is free of ferrous particles. Any such particles deposited in bottom of tank may cause it to rust.

Thoroughly clean interior and exterior of pasta cooker regularly. Do not use wire brushes on pan. Clean using a mild detergent and a hot water solution using soft cloth or a soft bristled brush. Dry appliance thoroughly using a dry clean cloth.

NOTE: To prevent rust forming on steel components, ensure that detergent or cleaning material has been entirely removed after each cleaning process.

Stainless Steel Surfaces

- a. Clean interior and exterior surfaces of pasta cooker with hot water, a mild detergent solution and a soft scrubbing brush. Note that gas control knobs are a push fit onto gas and water control valve spindles and can be removed when cleaning the control panel.
- b. Baked on deposits or discolouration may require a good quality stainless steel cleaner or stainless steel wool. Always apply cleaner when appliance is cold and rub in direction of grain.
- c. Dry all components thoroughly with a dry cloth and polish with a soft dry cloth.

Periodic Maintenance

NOTE: All maintenance operations should only be carried out by a qualified service person.

To achieve best results, cleaning must be regular and thorough and all controls and mechanical parts should be checked and adjusted periodically by a qualified service person. If any small faults occur, have them attended to promptly. Don't wait until they cause a complete breakdown. It is recommended that appliance is serviced every 6 months.

If appliance is not used for long periods, close gas shut-off valve upstream of appliance and clean appliance thoroughly.

Appliance should be inspected and gas exhaust flue cleaned by an authorized service person at least every 6 months.

Fault Finding

This section provides an easy reference guide to the more common problems that may occur during operation of your equipment. The fault finding guide in this section is intended to help you correct, or at least accurately diagnose problems with your equipment.

Although this section covers the most common problems reported, you may encounter a problem not covered in this section. In such instances, please contact your local authorised service agent who will make every effort to help you identify and resolve the problem. Please note that the service agent will require the following information:-

- **Model Trade Name and Serial Number of Appliance. (both can be found on Technical Data Plate located on appliance).**

Fault	Possible Cause	Remedy
Pilot Burners will not ignite or ignites with difficulty and will not stay alight.	Check gas supply is turned On .	Turn On gas supply.
	Check gas supply is low or empty.	Replenish gas supply.
	Thermocouple connection loose.	Tighten thermocouple connection. Replace any damaged connectors.
	Over temperature lead connection to interrupter on thermocouple is loose. Loose connections will cause resistance to millivolt circuit and result in pilot outage.	Tighten over temperature lead to interrupter on thermocouple.
	If sufficient pilot flame cannot be obtained, remove pilot orifice from pilot burner and check for pilot burner blockage and / or gas line blockage. Check correct size gas pipe used.	If connections OK, check for gas at the pilot burner by manually lighting the pilot burner. Call service provider.
	If pilot can be lit but flame too small to impinge on thermocouple.	Check adjustment of pilot flow by adjusting screw below control knob on gas control. Check gas supply.
	If pilot flame OK but goes out after control knob released (after holding in for approx. 30 secs).	Check for faulty thermocouple. Call service provider.
	If all of the above in pilot and thermocouple system checks out satis. but problem still persists.	Gas control valve is defective and needs replacement.
Pilot Burner delay in ignition of main burners.	Check operating pressure as shown in 'Installation' section.	Increase by adjusting pilot adjustment screw on gas control.
	Check pilot flame adjustment.	Pilot flame for main burner ignition should be approximately 1 inch long. Check pilot burner size is correct. (See 'Specifications' section).
Main Burners will not ignite or ignites with difficulty.	Insufficient gas pressure.	Check gas pressure and adjust as necessary.
	Main injector is blocked.	Remove main injector and clean or replace.
	Gas valve is faulty.	Replace. Call service provider.

PC8140G Pasta Cooker

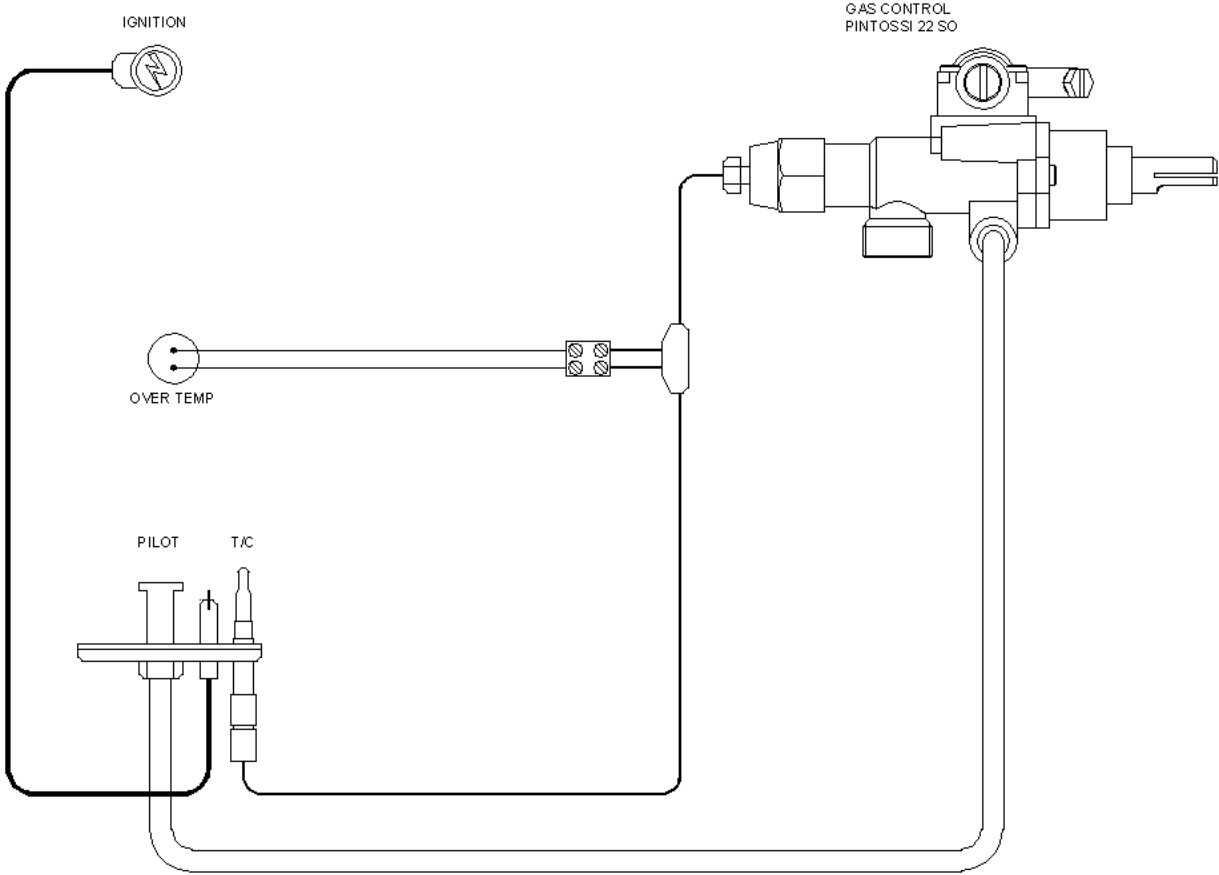

Gas Conversion and Specifications

Conversion Procedure



Caution

Ensure Appliance is isolated from gas supply before commencing servicing.

NOTE:

- These conversions should only be carried out by qualified persons. All connections must be checked for leaks before re-commissioning the appliance.
- Adjustment of components that have adjustments / settings sealed (e.g. paint sealed) can only be adjusted in accordance with the following instructions and shall be re-sealed before re-commissioning this appliance.
- For relevant gas specifications refer to 'Gas Specifications Tables' at rear of this section.

Main Burner

1. Remove the following:-
 - Gas control knob.
 - Water control knob.
 - Control panel.
2. Connect a manometer to upper test point (Line Pressure) on gas control valve. Turn **On** gas and ensure supply pressure is as shown in **Gas Specifications Table** at rear of this section.
3. Remove main burner injectors and replace with correct size injectors as shown in **Gas Specifications Table**.

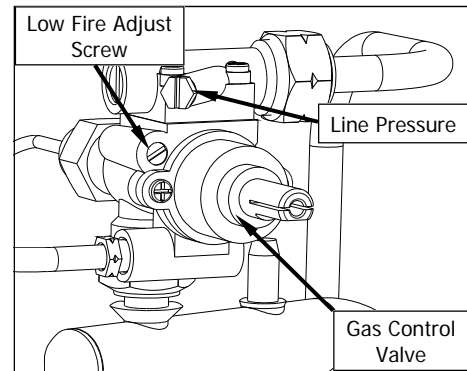

Pilot Burners

1. Remove the following:-
 - Gas supply tube to pilot burner.

NOTE: Appliances fitted with piezo igniter electrodes, remove electrode from mounting bracket before unscrewing pilot supply tube.

2. Remove pilot burner injector and replace with correct size injector as shown in 'Gas Specifications Table' at rear of this section.
3. Refit the following:-
 - Gas supply tube to pilot burner.
 - Piezo igniter electrode.

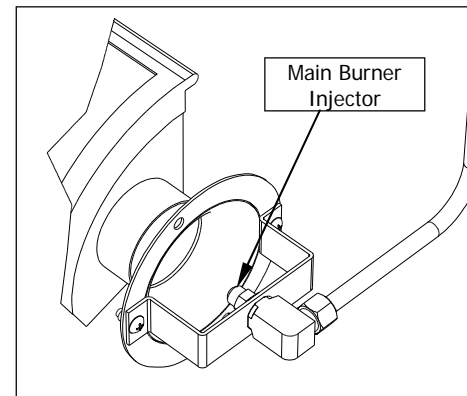

Low Fire Adjustment

1. Light main burners and check flame size on 'Low' position.
 - Adjust low fire adjustment screw on burner gas control valve to obtain desired flame size.

NOTE: 'Low Fire Screw' should be sealed with coloured paint on completion of low fire adjustment.

2. Refit the following:-
 - Gas control knob.
 - Water control knob.
 - Control panel.

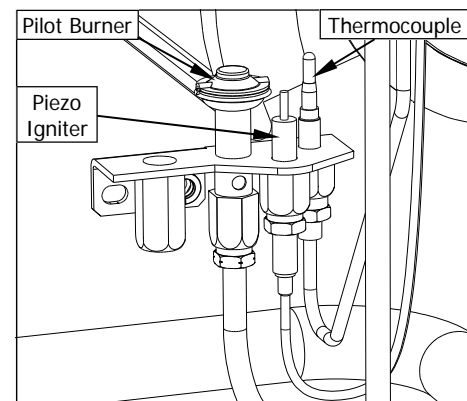

Gas Conversion and Specifications

Gas Regulator

NOTE: Gas regulator supplied is convertible between Natural Gas and LP Gas, but it's outlet pressure is fixed ex-factory and is NOT to be adjusted.

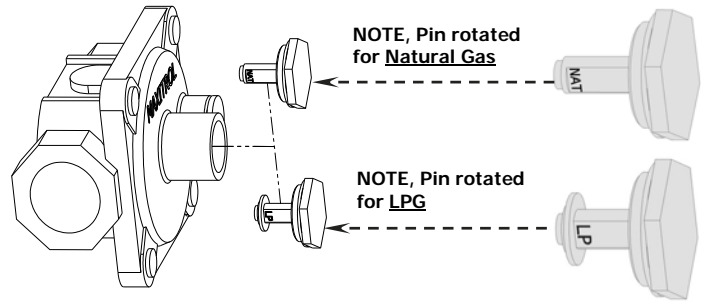

Gas Type Labels

On completion of gas conversion, replace gas type labels located at:-

- Rear of unit, above gas connection.
- Beside rating plate.

Commissioning

Before leaving installation;

1. Check all gas connections for leakage using soapy water or other gas detecting equipment.



Warning

DO NOT USE A NAKED FLAME TO CHECK FOR GAS LEAKAGES.



2. Carry out a 'Commissioning' check of appliance as shown in Installation Section of this manual.
3. Ensure any adjustments done to components that have adjustments / settings paint sealed are to be re-sealed.

NOTE: If for some reason it is not possible to get appliance to operate correctly, shut *Off* gas supply and contact supplier of this appliance.

Gas Conversion and Specifications

Gas Specifications

- Australia / New Zealand Only:



	Natural Gas.	LP Gas (Propane)
Main Burner Injectors	Ø 3.10mm	Ø 1.90mm
Pilot Burner Injectors	0.62	0.35
Low Fire Screw	Ø 1.55mm 2 turns out (c.c.w.)	Ø 1.55mm Fully In (c.w.)
High Fire Screw	Fully Out (c.c.w.)	Fully Out (c.c.w.)
Supply Pressure	1.13 - 3.40 kPa	2.75 - 4.50 kPa
Burner Operating Pressure	0.92 kPa (*)	2.6 kPa (*)
Gas Regulator Cap Screw		

- UK Only:

Appliance Classification

Category: II_{2H3P}.

Flue Type: A₁.

	Natural Gas (G20)	Propane (G31)
Main Burner Injectors	Ø 3.10mm	Ø 1.90mm
Pilot Burner Injectors	0.62	0.35
Low Fire Screw	Ø 1.55mm 2 turns out (c.c.w.)	Ø 1.55mm Fully In (c.w.)
High Fire Screw	Fully Out (c.c.w.)	Fully Out (c.c.w.)
Supply Pressure	20 mbar	37 mbar
Burner Operating Pressure	9.5 mbar (*)	27.7 mbar (*)
Gas Regulator Cap Screw		

NOTE: (*) Measure burner operating pressure at upper test point (Supply Pressure) on gas control valve located behind control panel, this is to be carried out with burner operating at 'High Flame' setting. Operating pressure is ex-factory set, through appliance regulator and not to be adjusted, apart from when carrying out gas conversion, if required. Refer to 'Gas Conversion and Specification' Section for further details.

Replacement Parts List

IMPORTANT:

Only genuine authorized replacement parts should be used for servicing and repair of this appliance. Instructions supplied with parts should be followed when replacing components.

For further information and servicing instructions, contact your nearest authorized service branch (contact details are as shown on reverse of front cover of this manual).

When ordering spare parts, please quote part number and description as listed below. If part required is not listed below, request part by description and quote model number and serial number which is shown on rating plate.

Controls

018094	Thermocouple.		
229702	Overtemp 115°.		
032190	Main Burner Injector	(LPG/Propane) -	ø 1.90mm.
032310	Main Burner Injector	(Nat Gas) -	ø 3.10mm.
018090K	Pilot Burner.		
018092	Pilot Injector	(LPG/Propane)	0.35.
018091	Pilot Injector	(Nat Gas) -	0.62.
229699	Gas Control Valve.		
229693	Gas Control Knob.		
235403	Water Valve.		
018095	Piezo H.T. Lead.		
227508	Piezo Ignitor.		
022575	Burner Kit.		

General

229837	Pasta Cooker Basket	320 x 165mm.	(Optional Accessory).
229836	Pasta Cooker Basket	165 x 165mm.	
229707	Pasta Cooker Basket Drain Tray.		
229682	Basket Support Frame.		
227856	Door Magnet.		
019390	Water Drain Valve.		
229823	Overflow Hose.		
227850	Adjustable Leg - 150mm.		

Regulator

228531	Regulator (RV48CLM) - (Natural Gas/LPG - convertible) - ¾" BSP female.
--------	--

Gas Conversion Kits

Model	Gas Type to Convert to:			
	Australia / New Zealand Only		UK Only	
	Nat. Gas	LPG	Nat. Gas	LPG
PC8140G	232061	232060	232061	232060

Accessories (Optional)

228793	Plinth Kit.
--------	-------------

