



code:

7919.70130.01

SERVICE TROLLEYS

GLASS DOOR HOT BANQUET TROLLEY (5 GN 2/1-100)

model:

OBAC 70130



Hygiene



Easy Maintenance



Heavy Duty



Efficiency



MAIN FEATURES

- * The convection-heated banquet trolleys can be used dry or with moist air, depending on what is best for your food.
- * Digital control with cabinet temperature display and setting. Fully compliant HACCP digital controls include visible alarms.
- * Large storage area suitable to contain 2/1 GN containers or shelves on anti-tilt pressed runners.
- * Optimized bottom to up forced air flow provide even temperature distribution and fast heating in any conditions.
- * Cabinet fitted with up to 70 mm thickness of polyurethane insulation for best insulating performance with 100% environmental protection.
- * Removable triple-chamber balloon magnetic gasket to improve insulation and reduce energy consumption.
- * Spacers on the sides-end ensure that the convection air in the interior of the banquet trolley can circulate all around, achieving temperature distribution which is as even as possible.
- * The slide-in convection-heated module can be removed particularly easily.
- * The water tank for the moist-air heating can also be removed conveniently.
- * Manual water refilling.

CONSTRUCTION

- * Constructed from the highest quality AISI 304 Stainless steel.
- * Interior base with corners, pressed from a single sheet.
- * Easy access to the main components for maintenance.
- * Lockable with magnetic strong handle door.
- * High density (40-42 kg/m³) polyurethane CFC and HCFC-free insulation.
- * Double glazed glass doors are self-closing and can be fully opened up to 270°
- * Right hinged door as factory setup.
- *

OPTIONS

- * Stainless steel shelf

ACCESSORIES

STANDARDS

- * EN 60335-1 European Standard relating to safety of household and similar electrical appliances
- *
- * EN 60335-2-49 European Standard relating to particular requirements for commercial electric hot cupboards





code:

7919.70130.01

SERVICE TROLLEYS

GLASS DOOR HOT BANQUET TROLLEY (5 GN 2/1-100)

model:

OBAC 70130

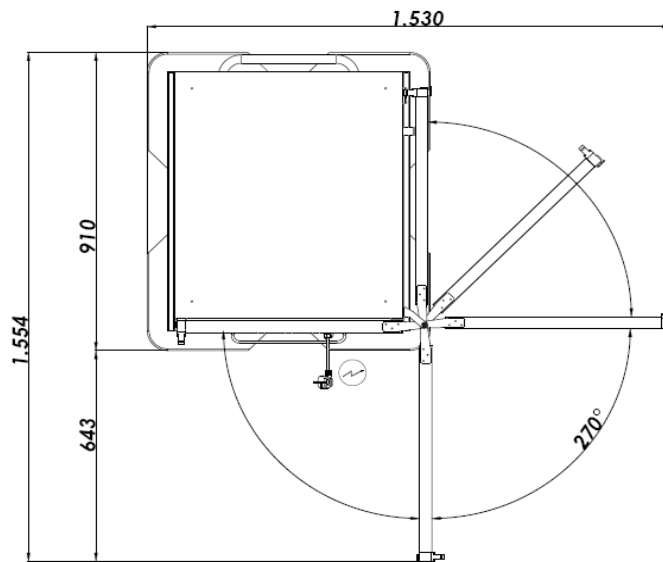
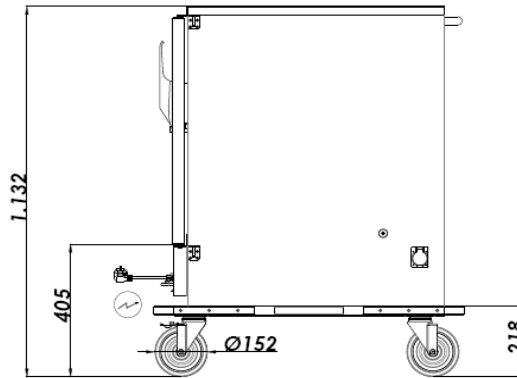
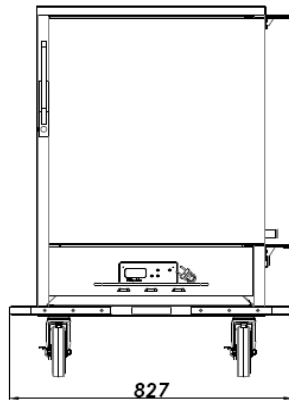

DIMENSIONS (Net)

* Width (mm)	827
* Depth (mm)	910
* Height (mm)	1132
* Weight (kg)	86

DIMENSIONS (Shipping)

* Width (mm)	
* Depth (mm)	
* Height (mm)	
* Weight (kg)	86
* Volume (m³)	1,21

TECHNICAL SPECIFICATIONS

- * cabinet capacity 5 GN 2/1 100mm
- * Regulating Temperature 70-85 °C



ELECTRICITY

- * Power: 2 kW
- * Supply Voltage: 230V - 240V / NPE 50 Hz
- * Protection Class: IP X4



WATER-IN

- * Cold Water Inlet: Pressure (min-max) bar kPa Temperature (min-max) °C
- * Hot Water Inlet: Pressure (min-max) bar kPa Temperature (min-max) °C
- * Hardness: F



DRAIN

*
*