



INSTALLATION, OPERATING AND SERVICING INSTRUCTION MANUAL



NC Series Commercial Noodle Cooker/Steamer **Model No's.: NC – 6 – R/S – 2RP/SP – CF – YC**

AGA Approval No.; AGA 8763 G

B&S Commercial Kitchens Pty Ltd

57 Plateau Road Reservoir VIC 3073 AUSTRALIA

Tel: +61 3 9469 4754 **Fax:** +61 3 94694504 **Web:** www.bscommercialkitchens.com

Please ensure this booklet is kept in a safe and prominent location for future reference.

The reproduction on or copying of any part of this booklet via any means is strictly forbidden unless agreed to in writing by the manufacturer.

Owing to continual product development and improvements to its products, B&S Commercial Kitchens Pty Ltd reserves the right to change the product specifications and design without prior notice.

Table of Contents

INSTALLATION, OPERATING AND SERVICING INSTRUCTION MANUAL	1
NC Series Commercial Noodle Cooker/Steamer	1
Product Specifications & Introduction	4
Table 1: Nominal Terminal Input Rates & Injector Sizes	4
Table 2: Standard Model General Information	5
Figure 1: Plumbing Connections -Black & Verro NC-6	5
Table 3: Plumbing Connections	5
Figure 2: Plumbing Connections -Black & Verro NC-9	6
Table 4: Plumbing Connections	6
IMPORTANT WARNINGS.....	6
Installation Instructions	8
Regulations	8
Data Label	8
Ventilation.....	8
Combustible Surfaces	8
Plinth Mount Models.....	8
Gas Connection	8
Pressure Test Point.....	9
Water Connection	9
Burner Adjustment	9
Before Leaving - Commissioning	9
Operating Instructions	10
IMPORTANT WARNING!.....	10
Lighting Instructions	10
Shutdown Procedure.....	11
Boil Out Procedure.....	11
Laundry Arm Activation	11
IMPORTANT NOTE!	11
Maintenance and Care.....	11
Servicing Instructions	12
Abnormal Operation	12
Panel Removing.....	12
Controls.....	12
Thermostat	12
Pilot Assembly.....	12
Piezo Assembly.....	13
Burners.....	13
Gas Valve.....	13
Table 4: Troubleshooting	14

Product Specifications & Introduction

Appliance Name:	NC Series Noodle Cooker This appliance may be branded as B+S Black and Verro
Manufactured By: Certificate Holder:	B&S Commercial Kitchen s Pty Ltd 57 Plateau Road Reservoir Victoria 3073 Tel; + 61 3 9469 4754 Fax: +61 3 9469 4504 E-mail: info@bscommercialkitchens.com
Model Number/s:	Supplied in various configurations. How to read model numbers; <u>(V)NC-6 - R/S - 2RP/SP - CF - YC - P</u> θ ω ε ρ τ ψ θ NC-6 – Noodle Cooker (All Models) ω R/S: No of Round/Square Noodle/Pasta Baskets per Pan 2 – Two Round/Square Baskets 4 – Four Round/Square Baskets 6 – Six Round/Square Baskets ε RP/SP: Number of Rectangular/Square Pots per Pan 1 – One Rectangular Pan 2 – Two Rectangular Pan 3 – Three Rectangular Pan ρ CF – Cheung Fun Steaming Tray τ YC – Yum Cha Steaming Tray ψ P – Plinth Mount E.G. NC4-1RP Is noodle cooker with tank provisions for four round baskets and one rectangular pot.
Approval Number:	AGA 8763 G
Gas Type/s:	Natural Gas & Propane Gas

We are confident that you will be delighted with your B&S Noodle Cooker, and that it will become the backbone of your kitchen. To ensure you receive the utmost benefit from your new B&S appliance, there are two important things you can do.

1. Ensure you read this booklet carefully and carefully follow the instruction given. Ensure that this booklet is kept in a safe and prominent location for future reference.
2. Should you be ensure of any aspect of the operation/performance, servicing and installation of the appliance, please contact your B&S dealer immediately. In most instances a phone call could answer your question.

Table 1: Nominal Terminal Input Rates & Injector Sizes

	Gas Type	Injector Size (mm)	MJ/h per pan	Test Point Pressure
NC-6	Natural Gas	1.85 mm	58	1.00 kPa
	Propane Gas	1.05 mm	50	2.60 kPa
NC-9	Natural Gas	1.90 mm	71	0.82kpa
	Propane Gas	1.15 mm	75	2.60kpa

Table 2: Standard Model General Information

	Weight (kg)	Overall Height (mm)	Overall Depth* (mm)	Overall Width* (mm)
NC-6	100	1,300	840	460
NC-9	130	1300	840	600
VNC-6	100	1030	840	460
VNC-9	130	1030	840	600

* Denotes Minimum
Overall Dimensions – Custom made appliances
 Height overall splashback : 1030mm - 1,300mm + adjustable legs.
 Height Plinth Mount : 980mm.
 Width : 1,840mm minimum with 4 pans. (NC-6)
 : 2400mm minimum with 4 pans (NC-9)
 Depth : 840mm minimum.

Figure 1: Plumbing Connections -Black & Verro NC-6

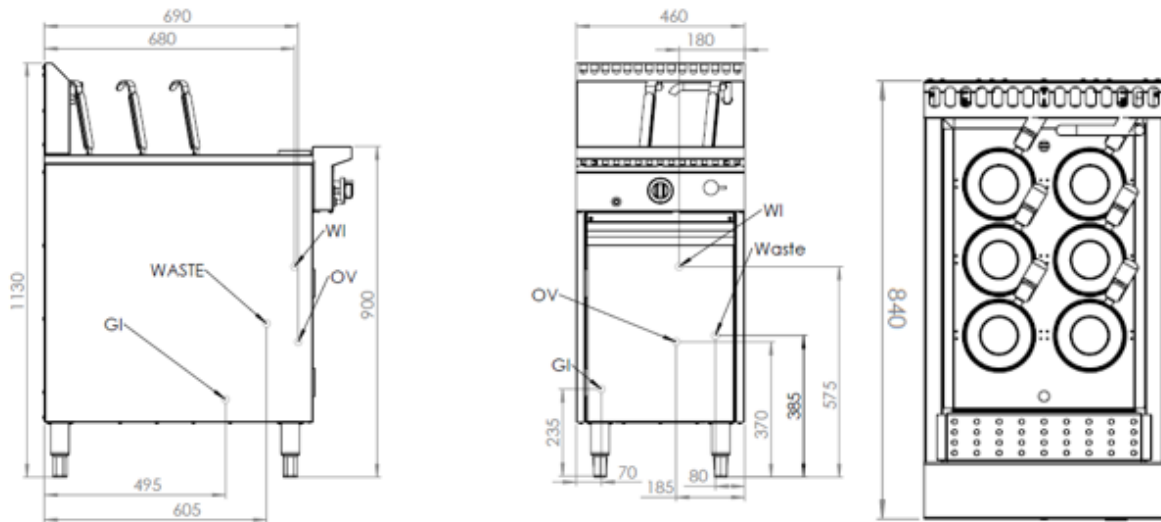

Table 3: Plumbing Connections

	Connection	Position from Floor (mm)	Position from Rear of Appliance (mm)	Position from LHS/RHS edge of Appliance (mm)
Water Inlet (WI)	1/2" Copper	575 (+/-5)	680 (+/-5)	180 (+/-5) LHS
Gas Inlet (GI)	3/4" male BSP	235 (+/-5)	495 (+/-5)	70 (+/-5) LHS
Over Flow (OV)	1" Hose	370 (+/-5)	690 (+/-5)	185 (+/-5) LHS
Waste	1" BSP	385 (+/-5)	605 (+/-5)	80 (+/-5) LHS

Plinth mount models have connections 170 mm lower.

Figure 2: Plumbing Connections -Black & Verro NC-9

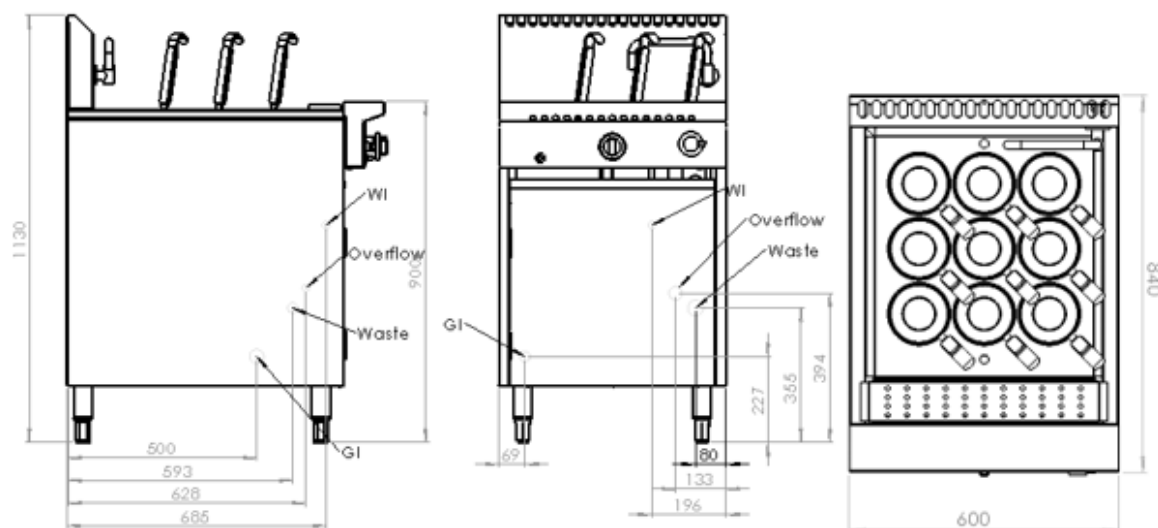

Table 4: Plumbing Connections

	Connection	Position from Floor (mm)	Position from Rear of Appliance (mm)	Position from LHS/RHS edge of Appliance (mm)
Water Inlet (WI)	1/2" Copper	575 (+/-5)	685 (+/-5)	195 (+/-5) LHS
Gas Inlet (GI)	3/4" male BSP	230 (+/-5)	500 (+/-5)	70 (+/-5) LHS
Over Flow (OV)	1" Hose	390 (+/-5)	630 (+/-5)	130 (+/-5) LHS
Waste	1" BSP	355 (+/-5)	605 (+/-5)	80 (+/-5) LHS



IMPORTANT WARNINGS

THIS APPLIANCE SHALL ONLY BE INSTALLED/SERVICED BY AN AUTHORISED INSTALLER.

THIS APPLIANCE MUST BE INSTALLED IN ACCORDANCE WITH THE SPECIFIED INSTRUCTIONS AND SPECIFICATIONS.

IMPROPER INSTALLATION OR OPERATION OF THIS APPLIANCE MAY RESULT IN PRODUCT FAILURE WHICH MAY LEAD TO PROPERTY DAMAGE, PERSONAL INJURY OR DEATH.

CAUTION MUST BE TAKEN WHEN OPERATING THIS APPLIANCE TO MINIMISE RISK OF FIRE. THE APPLIANCE MUST NOT BE LEFT ON UNATTENDED.

REGULAR INSPECTIONS BY AN AUTHORISED SERVICE PERSON ARE STRONGLY RECOMMENDED TO ENSURE PROPER AND SAFE FUNCTIONING OF THIS APPLIANCE.

AFTER ANY SERVICING OR ADJUSTING OF GAS CONNECTED COMPONENTRY, GAS LEAK TEST MUST BE CARRIED OUT TO ENSURE THERE ARE NO GAS LEAKING HAZARDS.

NEVER STORE ANY FLAMMABLE LIQUIDS/VAPOURS IN THE VICINITY OF THIS APPLIANCE. NEVER SPRAY AEROSOLS IN THE VICINITY OF THIS APPLIANCE WHILE IT IS IN OPERATION.

ENSURE ANY TRANSIENT PROTECTION IS REMOVED BEFORE INSTALLING THE APPLIANCE ENSURING ANY POSSIBLE DAMAGE TO THE APPLIANCE OR COMPONENTS/PARTS THAT MAY HAVE BEEN SUSTAINED DURING TRANSPORTATION IS REPORTED TO THE MANUFACTURER. ANY DAMAGE INCURRED DURING TRANSPORTATION MUST BE REPORTED IMMEDIATELY TO THE MANUFACTURER AND IT IS

RECOMMENDED THE APPLIANCE IS NOT INSTALLED UNTIL FURTHER INSTRUCTIONS FROM MANUFACTURER.

THIS APPLIANCE IS NOT INTENDED TO BE USED IN A MARINE ENVIRONMENT. ENSURE APPLIANCE IS INSTALLED IN A STABLE POSITION.

FAILURE TO FOLLOW THE INFORMATION PROVIDED IN THIS BOOKLET WILL VOID THE B&S WARRANTY AND MAY RESULT IN DAMAGE TO EQUIPMENT OR INJURY TO PERSONNEL

Please note that checking and adjusting of burner pressures on commercial catering appliances is an obligation of gasfitters.

The relevant legislation is as follows from the **Plumbing Regulations 2008** administered by the **Victorian Building Authority**:

Gas fitting work defined

- (1) Gas fitting work is the construction, installation, replacement, repair, alteration, maintenance, testing or **commissioning** of any pipe, **appliance**, flue, fitting, apparatus, control or other item that is involved with the supply or use of gas and that is fitted downstream of the outlet of a customer billing meter or a consumer's gas storage container

As per **AS/NZS5601.1**, clause 6.11.1, this gas appliance must be **commissioned** by a suitably authorized person who;

- (a) Installed the appliance when gas is available at the time of installation; or
- (b) Makes gas available to the appliance if gas was not available at the time of installation

As per **AS/NZS5601.1**, clause 6.11.3, the commissioning of this appliance shall take **full account of special design features, the manufacturer's instructions and the appliance safety requirements**.

As per **AS/NZS5601.1**, clause 6.11.4, the commission of this appliance shall include all of the following;

- (a) **Testing and purging** of the appliance and installation as appropriate.
- (b) Checks to ensure the appliance is in **safe working order**.
- (c) Ignition of each **burner** of the appliance and where necessary adjustment, in accordance with the **manufacturer's instructions**.
- (d) Testing of **flue** performance.
- (e) Testing of all **safety devices** for correct operation.
- (f) **Instruction** of the consumer, where available, on the safe and correct operation of the appliance and any auxiliary equipment.
- (g) Handing of the appliance **operating instructions** to the consumer, or if the consumer is not present, leaving the instructions in a suitable location on the premises.

Installation Instructions

Regulations

The appliance **must** be installed only by authorised persons and in accordance with the manufacturer's installation instructions, local gas fitting regulations, municipal building codes, AS 5601 – Gas Installations and any other health and safety regulations, local authority, gas, electrical any other statutory regulations.

Data Label

The data label is located on the front of the appliance. This appliance is suitable for Natural Gas and LPG. Please ensure that the gas supply matches the Data Label ensuring that the gas supply is correct for the appliance being installed and that adequate supply pressure and volume is available – refer to appliance data plate for MJ/h consumption, injector sizes of main burners/pilots, etc.

Ventilation

It is strongly recommended that the appliance is installed under an extraction hood (with a clearance of 1200mm to the grease filter). Ventilation must be in accordance with AS5601 - Gas Installations. In general, the appliance should have adequate ventilation for complete combustion of gas, proper flueing and to maintain temperature of immediate surroundings within safe limits.

The appliance shall be installed with an exhaust system comprising a hood and duct system. The hood shall be made of a material which is impervious to fat, grease and vapour. It shall be constructed so it can be readily and efficiently cleaned. Its inside faces shall be smooth and free of obstructions and all joints shall be grease tight.

The hood shall be located so as to effectively ventilate the noodle cooker and shall extend at least 150 mm beyond the perimeter of the unit. The exhaust duct system shall be adequately sized and shall not get connected to any other ventilating or exhaust system.

As suitable grease trap shall be provided to prevent grease vapour entering the exhaust system and shall be located to avoid constituting a fire hazard and be readily accessible for regular cleaning.

Unless adequately protected a hood and a duct shall be fitted at least 450 mm from any combustible material and so that the lower edge of the grease filter is no less than 1.1 meters above the cooking surface.

Combustible Surfaces

Clearances to combustible surfaces must be in accordance with AS/NZ 5601- *Gas Installations, clause 5.12.4.5*. Install on a flat/level, solid, fire resistance floor. Where the floor is not fire resistant, a fire resistant material shall be put under the appliance which shall have a fire resistance rating at least equal to that of 10mm millboard. The material shall extend at least 50mm beyond the edge of the appliance.

Leave a clearance of at least 200mm between the appliance and any combustible surface.

Leave clearance of at least 500mm from the front of the noodle cooker for services.

Plinth Mount Models

To plinth mount remove the legs and sit the unit on a concrete slab which should be the width of the appliance and 700mm deep. The height of the slab is determined by the installer.

Gas Connection

The gas connection is male $\frac{3}{4}$ " BSP and is situated at the rear of the appliance below the main body frame. The inlet is to the $\frac{3}{4}$ " pipe inlet located at the rear of the appliance.

This appliance is available in models for fixed installation or in models fitted with lockable wheels/castors

The appliance can be connected with rigid pipe as specified in AS/NZ 5601. For fixed installation models we recommend connection with 20mm copper tube and a certified isolating ball valve. For models fitted with lockable wheels/castors an Australian certified stainless steel braided flexible hose of adequate internal diameter must be

used. The fitting of the hose must comply with the relevant sections of gas installation code AS/NZS 5601. A restraining chain or wire must be fitted. We recommend a maximum length of 1.5 m for the flexible hose. When the appliance is in position all of the wheels/castors must have the built in lock on to prevent any movement of the appliance. An Australian certified isolating ball valve must also be fitted.

BEFORE CONNECTING NEW PIPE TO THIS APPLIANCE, THE PIPE MUST BE BLOWN OUT THOROUGHLY TO REMOVE ALL FOREIGN MATERIAL. FOREIGN MATERIAL IN THE BURNER AND GAS CONTROLS WILL CAUSE IMPROPER AND DANGEROUS OPERATION.

Connect to gas.

Pressure Test Point

All appliances that are dispatched from our factory are tested and adjusted according to the specifications for the required gas type. The regulator may require adjustment to achieve required gas pressure.

Check the burner pressure at the test point on the regulator. The test point pressure should be adjusted to 1.00 kPa – Natural gas or 2.60 kPa – LPG with the burners operating at maximum.

Water Connection

The water connection is 15mm copper and is situated at the rear of the appliance below the main body frame. The number of water inlets varies to client's particular needs. Water isolation valves are fitted to all water inlets. Ensure water is flushed through before final connection.

Water waste outlet is located on the left hand side of the waste gutter of the appliance (50mm connection). The water inlets and water drains should be connected with rigid copper pipes. **We strongly advise against the usage of plastic/PVC piping for connection of waste outlet.**

Burner Adjustment

The burners do not require any adjustments.

Note: If any problems are experienced in maintaining the burners, your local service agent should be contacted.

Before Leaving - Commissioning

Check **all** connections for gas leaks with soap and water. **Do not** use a naked flame for detecting leaks.

Ignite the pilot and main burners as prescribed below to ensure correct operation of gas valves, burners and ignition. When satisfied with the operation of the appliance, please instruct the user on the correct method of operation. Ensure that this instruction manual is left with owner of the appliance.

- A.** Set thermostat to lowest setting. Model with Alpha Brass valve do not have a thermostat.
- B.** Turn gas cock knob such that indicator knob points to 'OFF' (solid circle) position and allow 5 minutes for any gas in combustion chamber to escape (propane gas being heavier than air, may require forced ventilation).
Note: If knob is 'ON' (flame) position, turn anti-clockwise to 'PILOT' (spark) position. Then depress knob and turn to 'OFF' position.
- C.** Turn gas cock knob clockwise so indicator points to 'PILOT' position.
- D.** Then light the pilot manually while depressing the gas cock knob.
- E.** Keep knob fully depressed for thirty seconds.
- F.** Release gas cock knob. Pilot flame should continue to burn. Observe pilot is established. If pilot goes out when knob is released, repeat steps **A** to **F** allowing more time for thermocouple or pilot generator to heat up.
- G.** When pilot stays alight, operation of gas valve may be given over to thermostat by turning gas cock counter clockwise so indicator points to 'ON' position (flame).
- H.** Set thermostat (if fitted) to desired temperature.

In the event the appliance fails to operate correctly, check the following;

1. Data plate to ensure correct gas type and pressure (adjust if necessary).
2. Injector sizes – check against data plate and installation manual.
3. View pilot size and adjust if required.

In case appliance fails to operate correctly after all checks have been carried out, please contact;

B&S Commercial Kitchens Pty Ltd

Operating Instructions

WARNING!



- **DO NOT** spray aerosols in the vicinity of this appliance while it is in operation.
- **DO NOT** store or use flammable liquids or items in the vicinity of this appliance.
- Prior to lighting, smell area surrounding the appliance for gas (please note that as some gas types are heavier than air, we recommended the operator to also smell the floor around the appliance).
- In the event you smell gas: **DO NOT** light any appliance. **DO NOT** touch/ operate any electrical switch or phone in your building. Call local gas supplier **immediately** and follow their instructions.

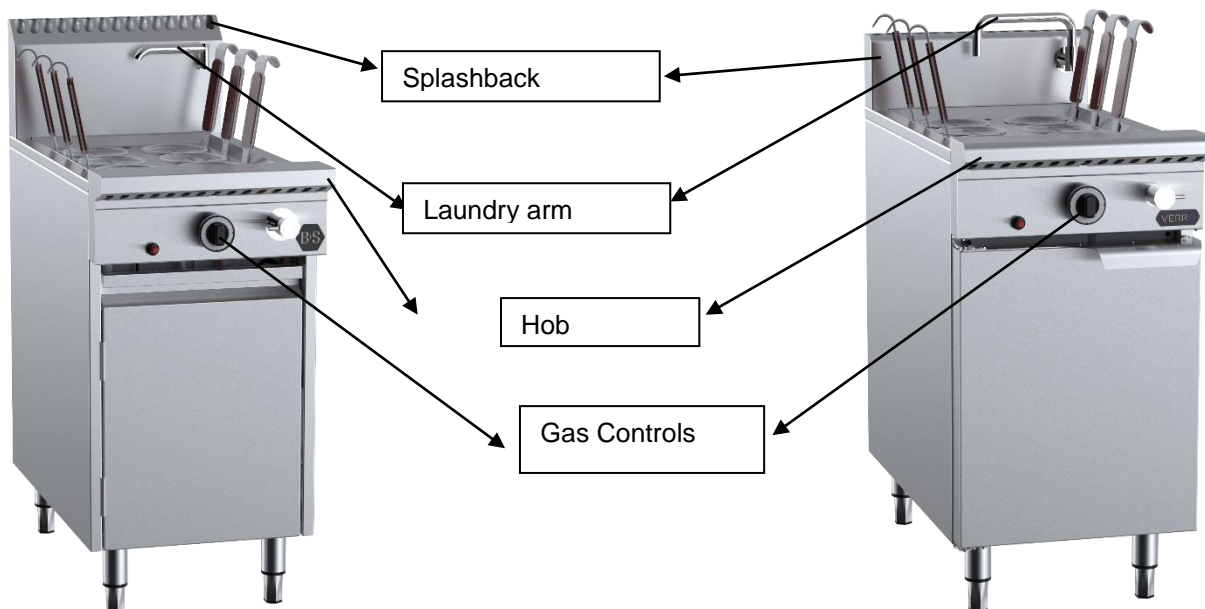

IMPORTANT WARNING!

ALWAYS ENSURE NOODLE COOKER PAN HAS WATER IN IT WHEN MAIN BURNERS AND PILOT LIGHT ARE ALIGHT.

To ensure noodle cooker pan is clean from any contamination resulting from the appliances manufacture, shipping and installation, the noodle cooker pan must be boiled out before first use.

NEVER LEAVE THE APPLIANCE UNATTENDED DURING THE BOIL-OUT PROCESS. IF THE BOIL-OUT SOLUTION OVER BOILS, IMMEDIATELY TURN THE NOODLE COOKER OFF AND LET THE SOLUTION COOL FOR A FEW MINUTES BEFORE RESUMING THE PROCESS.

BEFORE LIGHTING THE NOODLE COOKER, MAKE SURE THE NOODLE COOKER IS 'OFF' AND THE NOODLE COOKER PAN DRAIN VALVE(S) IS/ARE CLOSED. NEVER ALLOW BURNER TO OPERATE WITH TANK EMPTY. LIGHT ONLY WHEN THE WATER IS AT THE MINIMUM OPERATING WATER MARK LOCATED ON REAR PANEL OF PAN (WHEN LOOKING INTO PAN STANDING IN FRONT OF THE APPLIANCE).

Lighting Instructions

- Set thermostat to lowest setting. Models fitted with PEL valve do not have a thermostat.
- Turn gas cock knob such that indicator knob points to 'OFF' (solid circle) position and allow 5 minutes for any gas in combustion chamber to escape (propane gas being heavier than air, may require forced ventilation).
Note: If knob is in 'ON' (flame) position, turn anti-clockwise to 'PILOT' (spark) position. Then depress knob

and turn to 'PILOT' position.

- C. Turn gas cock knob clockwise so indicator points to 'PILOT' position.
- D. Then light the pilot using piezo ignitor (or manually) while depressing the gas cock knob.
- E. Keep knob fully depressed for thirty seconds.
- F. Release gas cock knob. Pilot flame should continue to burn. Observe pilot is established. If pilot goes out when knob is released, repeat steps **A** to **F** allowing more time for thermocouple or pilot generator to heat up.
- G. When pilot stays alight, operation of gas valve may be given over to thermostat by turning gas cock counter clockwise so indicator points to 'ON' position (flame).
- H. Set thermostat (if fitted) to desired temperature.

Shutdown Procedure

- A. Set thermostat to lowest setting. Models fitted with PEL valve do not have a thermostat.
- B. Turn gas cock knob such that indicator knob points to 'OFF' (solid circle) position and allow 5 minutes for any gas in combustion chamber to escape (propane gas being heavier than air, may require forced ventilation).
- C. Observe pilot frame is extinguished.

Boil Out Procedure

1. Prior to lighting burner, ensure noodle cooker drain valve is closed.
2. Fill noodle cooker pan with a mixture of cold water and dishwashing detergent up to the bottom of the water level line in the pan.
3. Operate the appliance as described in LIGHTING PROCEDURE above.
4. Simmer the solution for approximately one hour and turn off main burner and allow solution to cool.
5. Add approximately 5 litres of cold water into the pan and stir.
6. Open drain valve and drain the solution into a suitable container and then clean the pot thoroughly.
7. Close drain valve and rinse the fryer pan a couple of times by filling the pan with clean water and draining.
8. Dry the pan thoroughly with a clean/dry towel.

Laundry Arm Activation

The water tank must be filled with water whenever the burners are in use to prevent the base of the pan from buckling and distorting. To activate;

1. Locate spindle on front panel.
2. Turn spindle anti-clockwise to activate water.
3. Adjust as necessary.
4. Turn spindle clockwise to de-activate water.

IMPORTANT NOTE!

A SMALL AMOUNT OF TRICKLING WATER MAY BE REQUIRED TO RUN INTO THE PAN WHILST IN OPERATIONS TO ENSURE ADEQUATE WATER SUPPLY TO THE TANK, ENSURE EXCESS STARCH CREATED DURING COOKING PROCESS EXITS VIA THE OVERFLOW PIPE AND ENSURE WATER PURITY.

Maintenance and Care

To ensure longevity and continued performance efficiency of your appliance, a good cleaning and maintenance program is paramount. In general, the use of steel wool abrasive cloths/cleaners/powders **should not** be used to clean this appliance.

Daily Checks & Service

- Look for any foreign materials in burner area, leaks, damaged knobs and any other signs that the stock pot table is not ready and safe for operation. Inspect burner area and ensure pilots are in position near the burner, and that the pilot flame when ignited is blue in color and approximately 20-40mm in length. If fitted with thermocouple, ensure pilot flame is in contact with it. Call the manufacturer if you see any problems. Always ensure that area surrounding pilot and thermocouple is clear of any fats, oils or foodstuffs.
- Clean the exterior surfaces of the stock pot with a clean, damp cloth soaked with mild detergent to remove any food stuffs, oils, dust and any other materials.
- Ensure the primary water drain (located in gutter) is cleared of any food stuffs during operation of the appliance and on completion of use of the appliance.
- The spillage trays located under the main body of the appliance should be removed (by pulling out) and any carbonized foodstuffs and oils should be removed using a clean, damp cloth soaked in a mild detergent.

Yearly Checks & Service

- The appliance should be inspected and adjusted periodically by a qualified service person as part of any kitchen maintenance program.
- B&S recommends that this appliance is inspected at least annually by an authorised service technician as follows:
 - Inspect the table inside-out for excessive build-up of any fats, oils and foodstuffs.
 - Inspect that the burners and other components (i.e. pilots, thermocouples, etc.) are in good condition and functioning properly.
 - Inspect all gas connections for leaks and ensure all connections are tightened properly.
 - Ensure burner manifold pressure is in accordance with that specified on the data plate of the appliance.
 - Inspect all gas connections for leaks and ensure all connections are tightened properly.

In case of difficulties, contact B&S Commercial Kitchens Pty Ltd or their authorised service agent.

Servicing Instructions



WARNING!

- Servicing shall be carried out by authorized personnel **only**. Failure to do so will void the B&S warranty and may result in damage to equipment or injury to personnel.
- Before commencing any disassembly/ assembly of gas controls, please ensure the gas supply is turned off (isolated).

FAILURE TO DO SO WILL VOID B&S WARRANTY AND MAY RESULT IN DAMAGE TO EQUIPMENT OR INJURY TO PERSONNEL.

Abnormal Operation

Any of the following are considered to be abnormal operation and may require servicing;

- Incomplete ignition of burner/burner failing to keep alight.
 - Check burner is not blocked.
- Yellow tipping of the burner flame.
 - Check aeration of burner.
- Gas valves which are difficult to turn.
- Burner failing to keep alight.

Panel Removing

1. It is not necessary to remove any side or back panels for servicing the unit.
2. To remove the front panel, it will be necessary to pull off the thermostat control knob then undo the two screws holding the panel to the front hob section.

Controls

If gas control fails to operate, check the following;

1. The thermocouple is in the pilot flame. The thermocouple must be hot in order to generate energy to operate an electromagnetic system to lift and maintain open the control valve.
2. To do so, it is necessary to generate approximately 650 milli-volts. If not functioning correctly, the thermocouple should be replaced.
3. Check both main and safety thermostats switching systems. If thermostat is malfunctioning, it should be replaced.

Thermostat

1. Pull thermostat knob off and unscrew thermostat from control panel.
2. Remove control panel.
3. Remove both terminals from the thermostat.
4. Remove thermostat capillary gland and remove thermostat bulb.
5. To fit new thermostat, reverse the above procedures

Pilot Assembly

1. Undo the two screws holding the pilot bracket assembly located on the front shield behind the gas valve.
2. Gently pull the pilot assembly bracket down and outwards.
3. To change thermopile

- a. Undo locking screw holding thermopile to pilot assembly bracket and gently pull the thermopile down.
 - b. Undo terminal screws on located on 'TH TP' and 'TP' on main gas valve.
 - c. Replace with new thermopile and assemble in reverse order.
4. To change thermocouple
- a. Undo locking screw holding thermocouple to pilot assembly bracket and gently pull the thermocouple down.
 - b. Undo thermocouple screw located in the main gas valve.
 - c. Replace with new thermocouple and assemble in reverse order.
5. To change new pilot assembly
- a. Follow steps 1 and 2.
 - b. Undo the two screws on the pilot mounting bracket and pilot bracket.
 - c. Follow procedures 3. A. and 4. A. listed above.
 - d. Remove piezo lead from piezo.
 - e. Undo pilot gas flexible tube.
 - f. Change pilot assembly over and reassemble in reverse order.

Piezo Assembly

1. To change piezo ignitor
- a. Undo the piezo screw located on the back of the piezo ignitor located on the bottom right hand side of the main gas control
 - b. Gently remove piezo lead from rear of piezo ignitor
 - c. Replace piezo ignitor and replace in reverse order
2. To change piezo lead
- a. Gently remove piezo lead from rear of piezo ignitor.
 - b. Gently remove piezo ignitor lead from pilot assembly
 - c. Replace with new lead and assemble in reverse order.

Burners

1. To change/service burner (ensure burner is cool to prevent injury to service person)
- a. Undo the wing nut(s) located on the front burner support channel.
 - b. Gently lift the front section on an angle and pull forwards so that the rear of the burner is removed off the burner injector.
 - c. Allow the rear section of the burner to fall outside the combustion chamber and move backwards so that burner is clear of the combustion area.
 - d. Reassemble in reverse order.

Gas Valve

1. To remove/change/service main gas valve.
- a. Undo barrel union on right hand side of gas valve
 - b. Undo flexible tube to main gas valve from burner manifold.
 - c. Undo flexible tube from pilot assembly to main gas valve.
 - d. Undo terminals from thermostat (if fitted) on the main gas valve.
 - e. Undo thermocouple leading into main gas valve
 - f. Remove piezo igniter as described under PIEZO ASSEMBLY 1. a. above
 - g. Undo mounting screws on the gas valve support bracket.
 - h. Gently remove main gas valve
 - i. Reassemble in reverse order

Table 4: Troubleshooting

FAULT	POSSIBLE CAUSE	CHECKS
Pilot light not igniting	Blockage of pilot	Check pilot injector is not blocked as described in servicing instructions – pilot and flame safeguard
	Adjustment of pressure from flame failure control	Check gas pressure to pilot as described under servicing instructions – adjustments
Pilot light not establishing	Positioning of thermocouple	Check connection of the thermocouple to the control is not loose. Adjust positioning of thermocouple to ensure pilot flame is hitting thermocouple
	Faulty thermocouple	Contact manufacturer or authorised service agent
	Faulty flame failure control valve	Contact manufacturer or authorised service agent
Pilot established, main burner not lighting	Faulty thermocouple	Contact manufacturer
	Faulty Thermopile	Contact manufacturer
	Faulty flame failure control valve	Contact manufacturer
Telescopic laundry arm constantly running (on water/deck cooled wok tables)	Worn tap washer	Change washers in tap assembly. Contact manufacturer or authorised service agent

To obtain further service information concerning this appliance, please contact;

B&S Commercial Kitchens Pty Ltd

57 Plateau Road

Reservoir VIC 3073

Tel.: + 61 3 9469 4754

Fax.: + 61 3 9469 4504

E-mail: info@bscommercialkitchens.com



STANDARD WARRANTY CONDITIONS

B+S Commercial Kitchens Pty Ltd of 57 Plateau Road, Reservoir, Victoria (hereinafter called 'B+S') undertakes by this warranty, that B+S or its agent will pay for the cost of labour and parts which B+S or its agent find defective for:

K+ Range - fifteen (15) months from date of installation.

B+S Black Range - eighteen (18) months from date of installation.

Verro Range - twenty four (24) months from date of installation.

The liability of B+S under this warranty is limited to the repair or replacement of defective goods or components. All other costs including, without limitation, cartage, carriage and installation shall be borne by the purchaser.

Warranty labor is supplied free of charge during business hours (8 a.m. to 4 p.m. AEDST) Monday to Friday. Should warranty work be requested outside of our normal working hours, a labour charge will be applied equivalent to a normal hour rate, with out of hours penalty rates. Penalty rates amount must be borne by the purchaser. Claims for non-covered parts, no faults found, travel over 100km or other items outside our standard terms and conditions will be chargeable.

1. This warranty applies only for mainland Australia and Tasmania, and does not cover any service consequent upon accident, alterations, misuse, fire, flood or act of God.
2. This warranty is valid only if the appliance has been installed in accordance with local regulations by a duly authorized person, and the B+S installation instructions provided with the appliance. If in doubt, please contact B+S or their representative for further information. No responsibility will be accepted for defects or damages by improper installation, for changes to the product not authorized by B+S or for the operation outside the technical specifications of the appliance.
3. This warranty is conditional upon the appliance being used in normal commercial catering operations.
4. This warranty is the only express warranty given by the Company. No person has authority to change or to add to these obligations and liabilities.
5. The Company has the right to determine whether or not a fault is caused by faulty workmanship or material or that any part is defective.
6. This warranty does not apply to any loss suffered through or resulting from the non-operation or the ineffective operation of the cooking appliance or any part of the cooking appliance.
7. This warranty does not extend to goods and components thereof manufactured either entirely or substantially of glass or similar substances, light globes, infrared or quartz tubes and electrical controls or elements.
8. While the goods are in custody of the seller for investigation or repair, they shall be at the risk of the purchaser and no liability shall attach to the Company, its servants or agents for any damage occasioned to, or loan of, the goods whatsoever.

The Purchaser must give notice to the Company immediately upon it becoming aware of the alleged defect and in any event before the expiration of the appropriate warranty period.

B+S will endeavor to have a service technician on site for all warranty service requests within a 24 hour period or by end of next business day at the latest. All warranty requests must be in writing by either lodging a warranty request through B+S website or by emailing clientservices@bscommercialkitchens.com. Details of installer such as contact name, business name, telephone number and license number must be provided to avoid any delays.

9. Nothing in this warranty, however, shall be construed as affecting any rights you may have under the Trades Practices Act or any other Commonwealth or State Legislation which gives you rights which cannot be modified or excluded by agreement.

10.SPECIAL PROVISIONS

- Cleaning of spark and ignition sensors is not covered by warranty. Damage caused by oils, water and foodstuffs falling into burner area will not be covered under warranty.
- Cleaning of burners due to blockage of burner orifices caused by foodstuffs and/or oils is not covered by warranty.
- Breakage of pilot knobs, knee valve handles and knee wands are not covered under warranty.
- Thermocouples, piezo leads and ignitors are only covered by twelve (12) months parts and labour across K+, B+S Black and Verro ranges.

B+S Commercial Kitchens 57 Plateau Road,
Reservoir Victoria 3073 Australia

+61 3 9469 4754 | info@bscommercialkitchens.com | bscommercialkitchens.com