



# HHS22E16

## HOT HOLDING CABINET

### Features & Advantages of CIRCUM HEAT®

- CIRCUM Heat (patented) technology is being used in the wide range of DSS holding cabinets and banquet carts. Heating pads (heating elements) are located in the side walls of the holding cabinets and banquet carts to provide and ensure an even and gentle heat distribution throughout the entire cabinet.
- No water is needed and required in the DSS holding cabinets and banquet carts while using the CIRCUM Heat. Adding water vapor to held foods lessens taste and can also result in “washed out” or drying out food before it’s even served. Gentle radiant heat in a sealed and static holding environment is all that is needed to keep the food hot, flavorful and ready to serve for hours.
- CIRCUM Heat equipment will help saving more energy and money as CIRCUM Heat consumes only one-half to even one-third of the energy of any conventional method of heating/warming equipment’s.
- CIRCUM Heat keeps foods at safe and even temperatures while retaining the maximum amount of natural food product moisture as there is no fan and no high-density heating elements that are used in the CIRCUM Heat holding cabinets and banquet carts. Using fan and high-density heating elements will result in drying out the food products and changing the texture of the food products to be served.
- Side racks with integrated gaps ensure better air circulation and even temperature distribution.
- Temperature variance in the CIRCUM Heat products is very minimal, only a few degrees from top to bottom of the cabinet, while temperature fluctuations in almost all other top brands’ are easily over 15 degrees and in some even up to 25 degrees.
- Designed to adapt to 1/1 and/or 2/1 GN pans.
- *As an available option (factory quote & build), this model can be equipped with handles and full-perimeter bumper for catering needs and services.*



### General Specifications

- #304 Stainless steel interior & exterior.
- Ultra low energy consumption with a thermostatic control.
- Two (2) separate independent compartments with individual temperature controls.
- Zero ODP injected polyurethane insulation for environmental protection.
- Factory preset temperature to operate between 76°C and 86°C to have a better control on temperature while having rooms for a possible adjustment of temperature within in a safe temperature range.
- Electronic controller with a LCD display.
- Safety cut out switch – heated.
- Color-coded control panel (in red color for the heated cabinets) for easy identification of the nature of the cart.
- Interior curved corners/edges for easy cleaning and hygiene & sanitation purposes.
- Gastronorm shelving system with anti-tilt slides.
- Mechanical parts are easily accessible for quick servicing & maintenance.
- Two (2) sets of stylish and robust door handles on each side of the cart for easy transportation.
- Two (2) lockable self-closing doors.
- Door handles are equipped with lock.
- Four (4) heavy-duty casters; two (2) swivel and two (2) with brake.
- Manufacture code: DS-CH-GN32

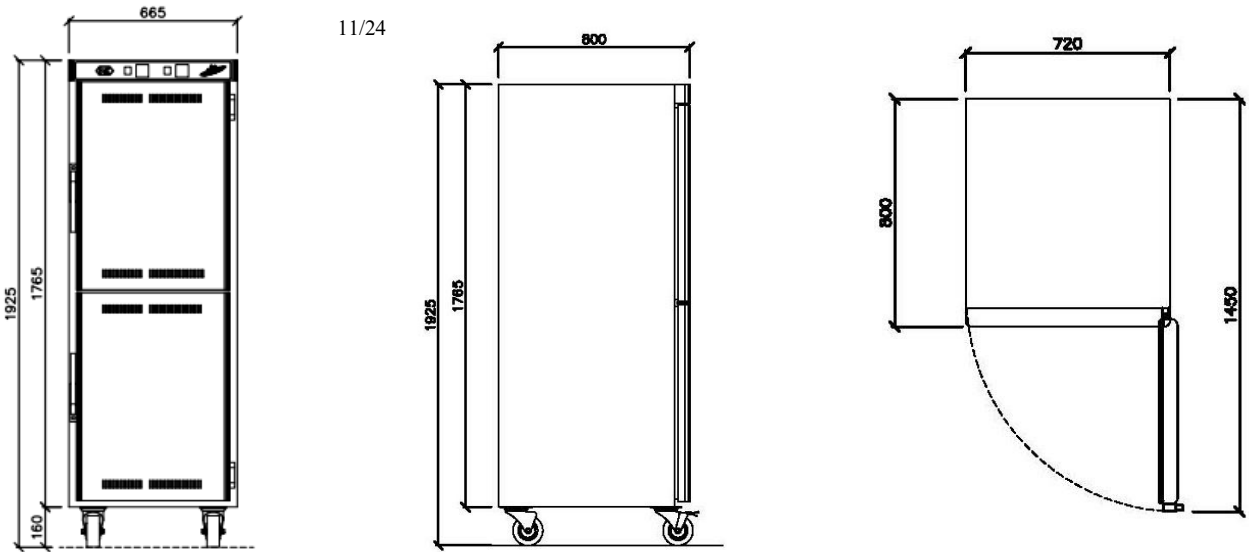

11/24

### Technical Specifications

Model	Pan / Product Capacity	Temperature	Voltage	Phase	Cycle	Amps	Watts	Cord Length
DS-CH-GN32	16 GN 1/1 pans in 65mm depth or 8 GN 1/1 in 100mm depth; or 8 GN 2/1 pans (in each compartment)	+27 / +93°C	220-240V	1	50/60 Hz	8.0	2000	2000mm

### Dimensions & Weights

Interior Dimensions Each Compartment (W x D x H in mm)	Exterior Dimensions (W x D x H in mm)	Product Net Weight (kg)	Shipping Dimensions with Wooden Crating (W x D x H in mm)	Shipping Weight with Wooden Crating (kg)
586 x 681 x 736	720 x 800 x 1925	156	810 x 945 x 2093	188

### INSTALLATION REQUIREMENTS

- Cart must be installed level.
- Cart must not be installed in any area where it may be affected by steam, grease, dripping water, extreme temperatures, or any other severely adverse conditions.

### CLEARANCE REQUIREMENTS (for ventilation)

Minimum: 50mm at the back, 50mm at the top, and 25mm at both sides. On-site venting for proper airflow must also be provided for built-in counter installations.

