



EVOLUTIONSERIES

INSTALLATION AND OPERATION MANUAL

GAS COOKTOP

Series

G512

G514

G516

G518



Date Purchased	_____
Serial Number	_____
Dealer	_____

Service Provider	_____

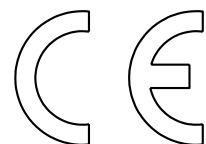

For use in GB, IE & DK

MANUFACTURED BY

Moffat Limited
PO Box 10001
Christchurch
New Zealand
Ph: (03) 389 1007
Fax: (03) 389 1276

WORLD-WIDE BRANCHES**UNITED KINGDOM**

Blue Seal
Unit 67, Gravelly Business Park
Gravelly Park
Birmingham
West Midlands
B24 8TQ
Ph: (121) 327 5575
Fax: (121) 327 9711

UNITED STATES

Moffat Inc
3765 Champion Blvd
Winston-Salem
North Carolina 27115
Ph: (336) 661 0257
Fax: (336) 661 9546

CANADA

Serve Canada
22 Ashwarren Road
Downview
Ontario M3J1Z5
Toll Free: 800 263 1455
Ph: (416) 631 0601
Fax: (416) 631 0315
info@servecanada.com
www.servecanada.com
www.moffat.com

NEW ZEALAND**Christchurch**

Moffat Limited
PO Box 10-001
16 Osborne Street
Christchurch
Ph: (03) 389 1007
Fax: (03) 389 1276

Auckland

Moffat Limited
4 Waipuna Road
Mt Wellington
Auckland
Ph: (09) 574 3150
Fax: (09) 574 3159

AUSTRALIA**Victoria**

Moffat Pty Limited
740 Springvale Road
Mulgrave, Melbourne
Victoria 3171
Ph: (03) 9518 3888
Fax: (03) 9518 3838

New South Wales

Moffat Pty Limited
3/142 James Ruse Drive, Rose Hill
PO Box 913, Smithfield
Sydney, N.S.W. 2142
Ph: (02) 8833 4111
Fax: (02) 8833 4133

Western Australia

Moffat Pty Limited
67 Howe Street
Osbourne Park
WA 6017
Ph: (08) 9202 6820
Fax: (08) 9202 6836

Queensland

Moffat Pty Limited
30 Prosperity Place
Geebung, Brisbane
Queensland 4034
Ph: (07) 3630 8600
Fax: (07) 3630 8623

The reproduction or copying of any part of this manual by any means whatsoever is strictly forbidden unless qualified previously in writing by the manufacturer.

In line with policy to continually develop and improve its products, Moffat Ltd. reserves the right to change the specifications and design without prior notice.

Blue Seal Gas Cooktops

G512	Gas Cooktop 300mm wide.
G514	Gas Cooktop 600mm wide.
G516	Gas Cooktop 900mm wide.
G518	Gas Cooktop 1200mm wide.

Introduction	2
Specifications	3
Model Numbers Covered in this Specification	
General	
Gas Supply Requirements	
Gas Connection	
Dimensions	5
Installation	10
Installation Requirements	
Unpacking	
Location	
Clearances	
Assembly	
Fitting the Leg Stand to the Cooktop	
Gas Connection	
Commissioning	
Operation	14
Operation Guide	
Description of Controls	
Open Burners ('F' - Flame Failure Option)	
Open Burners ('PF' - Pilot and Flame Failure Option)	
Griddle	
Cleaning and Maintenance	17
General	
After Each Use	
Daily Cleaning	
Weekly Cleaning	
Periodic Maintenance	
Fault Finding	21
Gas Conversion and Specifications.....	22
Conversion Procedure	
Gas Specifications	
Replacement Parts List.....	29

Introduction

We are confident that you will be delighted with your BLUE SEAL COOKTOP, and it will become a most valued appliance in your commercial kitchen.

To ensure you receive the utmost benefit from your new BLUE SEAL COOKTOP, there are two important things you can do.

Firstly:

Please read the instruction book carefully and follow the directions given. The time taken will be well spent.

Secondly:

If you are unsure of any aspect of the installation, instructions or performance of your appliance, contact your BLUE SEAL dealer promptly. In many cases a phone call could answer your question.

CE Only:

These instructions are only valid if the country code appears on the appliance. If the code does not appear on the appliance, refer to the supplier of this appliance to obtain the technical instructions for adapting the appliance to the conditions for use in that country.

WARNING:

IMPROPER INSTALLATION, ADJUSTMENT, ALTERATION, SERVICE OR MAINTENANCE CAN CAUSE PROPERTY DAMAGE, INJURY OR DEATH. READ THE INSTALLATION, OPERATING AND MAINTENANCE INSTRUCTIONS THOROUGHLY BEFORE INSTALLING OR SERVICING THIS APPLIANCE.

WARNING:

INSTRUCTIONS TO BE FOLLOWED IN THE EVENT THE USER SMELLS GAS ARE TO BE POSTED IN A PROMINENT LOCATION. THIS INFORMATION SHALL BE OBTAINED BY CONSULTING THE LOCAL GAS SUPPLIER.

WARNING:

GREAT CARE MUST BE TAKEN BY THE OPERATOR TO USE THE EQUIPMENT SAFELY TO GUARD IT AGAINST RISK OF FIRE.

- **THE APPLIANCE MUST NOT BE LEFT ON UNATTENDED.**
- **IT IS RECOMMENDED THAT A REGULAR INSPECTION IS MADE BY A COMPETENT SERVICE PERSON TO ENSURE CORRECT AND SAFE OPERATION OF YOUR APPLIANCE IS MAINTAINED.**
- **DO NOT STORE OR USE GASOLINE OR OTHER FLAMMABLE VAPOURS OR LIQUIDS IN THE VICINITY OF THIS OR ANY OTHER APPLIANCE.**
- **DO NOT SPRAY AEROSOLS IN THE VICINITY OF THIS APPLIANCE WHILE IT IS IN OPERATION.**

CAUTION:

This appliance is;

- **For professional use and is to be used by qualified persons only.**
- **Only authorised service persons are to carry out installation, servicing and gas conversion operations.**
- **Components having adjustments protected (e.g. paint sealed) by the manufacturer should not be adjusted by the user / operator.**
- **DO NOT operate the appliance without the legs supplied fitted.**

Model Numbers Covered in this Specification

G512D-[1]-[2]	2 Open Burners.
G512C -[2]	300mm Griddle.
G514D-[1]-[2]	4 Open Burners.
G514C-[1]-[2]	2 Open Burners + 300mm Griddle.
G514B -[2]	600mm Griddle.
G516D-[1]-[2]	6 Open Burners.
G516C-[1]-[2]	4 Open Burners + 300mm Griddle.
G516B-[1]-[2]	2 Open Burners + 600mm Griddle.
G516A -[2]	900mm Griddle.
G518D-[1]-[2]	8 Open Burners.
G518C-[1]-[2]	6 Open Burners + 300mm Griddle.
G518B-[1]-[2]	4 Open Burners + 600mm Griddle.
G518A-[1]-[2]	2 Open Burners + 900mm Griddle.

- [1] - Open Burner Options;
 F - With Flame Failure Protection.
 PF - With Pilot and Flame Failure Protection.

- [2] - Base Stand Options;
 B - Bench Mount.
 CB - Cabinet Base (excluding G512 series).
 LS - Leg Stand (excluding G512 series).
 RB - Refrigerated Base (G516 and G518 series only).

General

A heavy duty, high efficiency Cooktop for modular kitchens. It has a high option Cooktop / Griddle arrangement and is available either on industrial adjustable feet or on robust rollers. Griddle options with 4 models of base unit available (except G512 Model). Fitted with either 'Individual Flame Failure' (F) or 'Pilot and Flame Failure' (PF) option for each open burner. Griddles are fitted with pilot, flame failure and piezo ignition as standard. Easy clean stainless steel external finish.

Gas Supply Requirements

- Non CE Only:

	Natural Gas	LP Gas (Propane)
Input Rate (N.H.G.C.)		
- each Open Burner	28 MJ/hr (26,540 Btu/hr)	28 MJ/hr (26,540 Btu/hr)
- each 300mm Griddle Section	21 MJ/hr (19,900 Btu/hr)	21 MJ/hr (19,900 Btu/hr)
Supply Pressure	1.13 - 3.40 kPa (4.5" -13.5" w.c.)	2.75 - 4.50 kPa (11" -18" w.c.)
Burner Operating Pressure	0.95 kPa (*) (3.7" w.c.)	2.6 kPa (*) (10.0" w.c.)
Gas Connection	See 'Gas Connection' information overleaf	

Specifications

- CE Only:

Appliance Classification

Category: **II_{2H3P} (20, 30 / 37).**

Flue Type: **A₁.**

		Natural Gas (G20)		Propane (G31)	
		Open Burner (each)	Griddle (each 300mm section)	Open Burner (each)	Griddle (each 300mm section)
Heat Input (nett)	Nominal	6.5 kW	5.5 kW	6.5 kW	5.5 kW
	Reduced	1.75 kW	1.85 kW	1.75 kW	1.95 kW
Gas Rate (nett)	Nominal	0.69 m ³ /hr	0.58 m ³ /hr	0.51 kg/hr	0.43 kg/hr
	Reduced	0.19 m ³ /hr	0.20 m ³ /hr	0.14 kg/hr	0.15 kg/hr
Supply Pressure		20 mbar		30 / 37 mbar	
Burner Operating Pressure		9.5 mbar (*)		26 mbar (*)	
Gas Connection		See 'Gas Connection' information overleaf			

* - The burner operating pressure is to be measured at the manifold test point with two burners operating at full setting. The operating pressure is ex-factory set, through the appliance regulator and is not to be adjusted, apart from when converting between gases, if required. (Refer to the 'Gas Conversion' section for details).

Gas Connection

Gas supply connection point is located at the rear of the appliance, approximately 130mm from the right hand side, 32mm from the rear and 655mm from the floor (55mm for bench top – **B** models) and is reached from beneath the appliance. (Refer to the 'Dimensions' section). With the exception of the G512C and G512D models which are 100mm from the right hand side, 32mm from the rear and 70mm from the floor.

Connection is 1/2" BSP male thread (for G512C and G512D models).

Connection is 3/4" BSP male thread (for all other models).

Dimensions for Bench Models

G512-B

(R) = Rating Plate Location for this option.

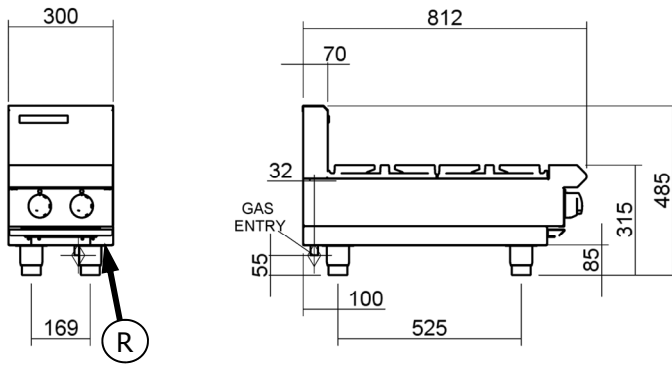

G514-B

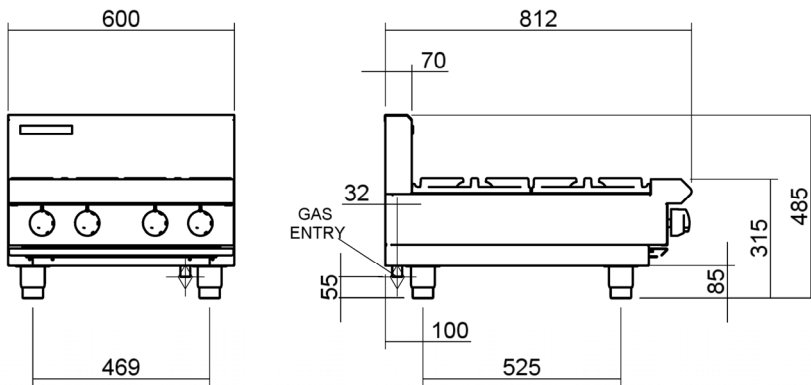

G516-B

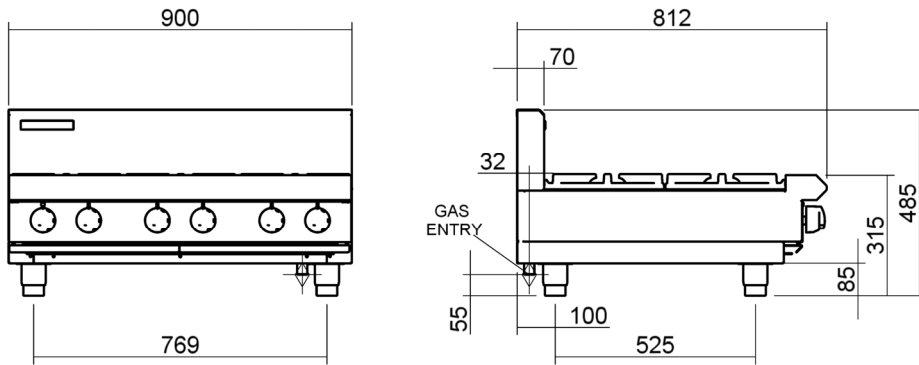

G518-B

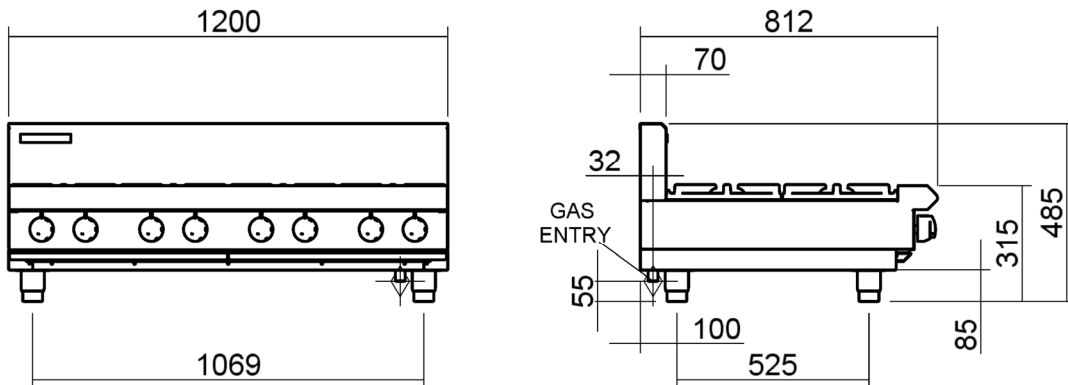

Refer to Page 9 for Cooktop Options

Dimensions

Dimensions for Cabinet Base Models

G512 models - not available in Cabinet Base option.

G514-CB

(R) = Rating Plate Location for this option.

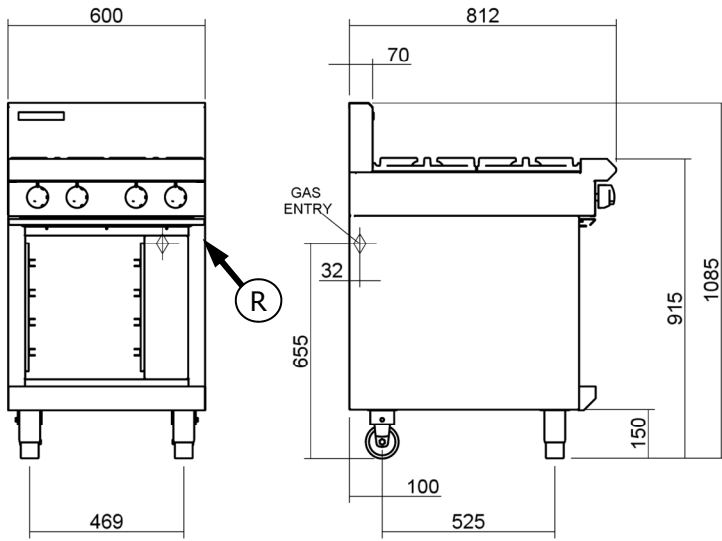

G516-CB

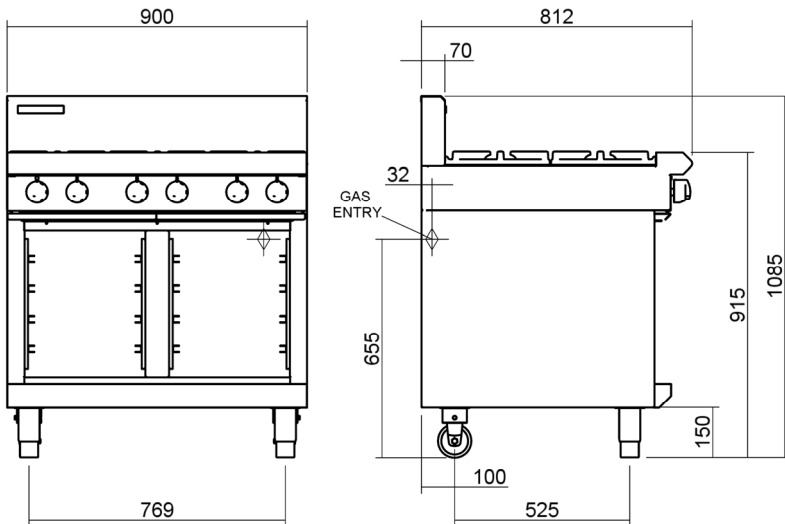

G518-CB

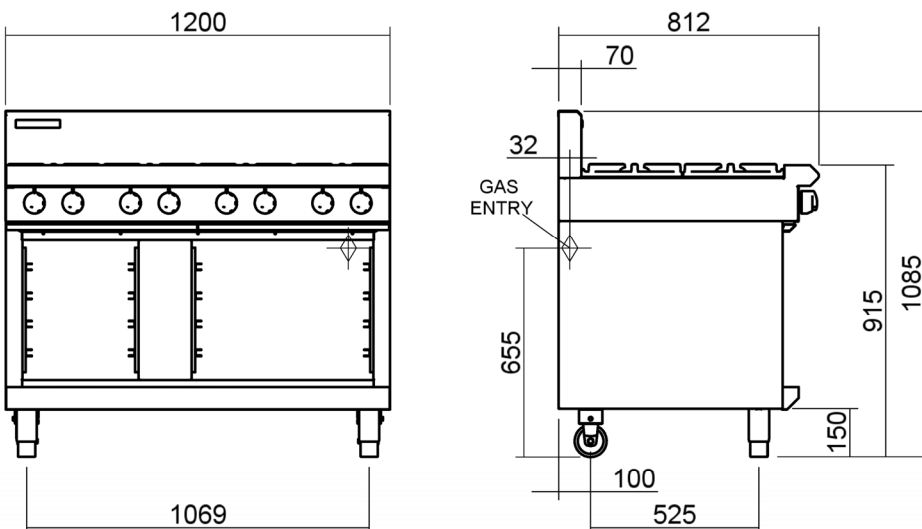

Refer to Page 9 for Cooktop Options

Dimensions for Leg Stand Models

G512 models - not available in Leg Stand Base option.

G514-LS

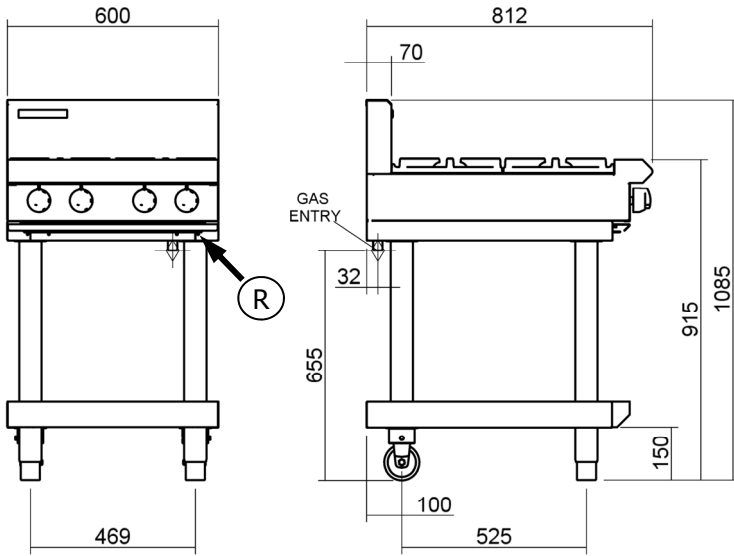

(R) = Rating Plate Location for this option.

G516-LS

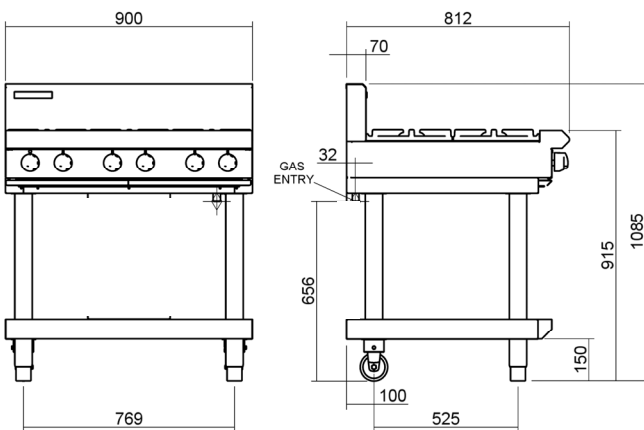

G518-LS

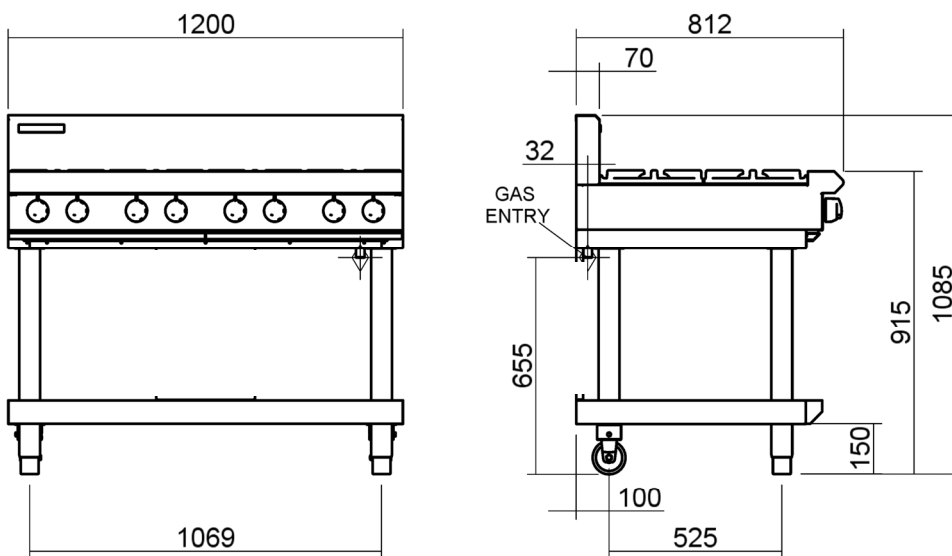

Refer to Page 9 for Cooktop Options

Dimensions

Dimensions for Refrigerated Base Models

G512 and G514 models - not available in Refrigerated Base option.

G516-RB

(R) = Rating Plate Location for this option.

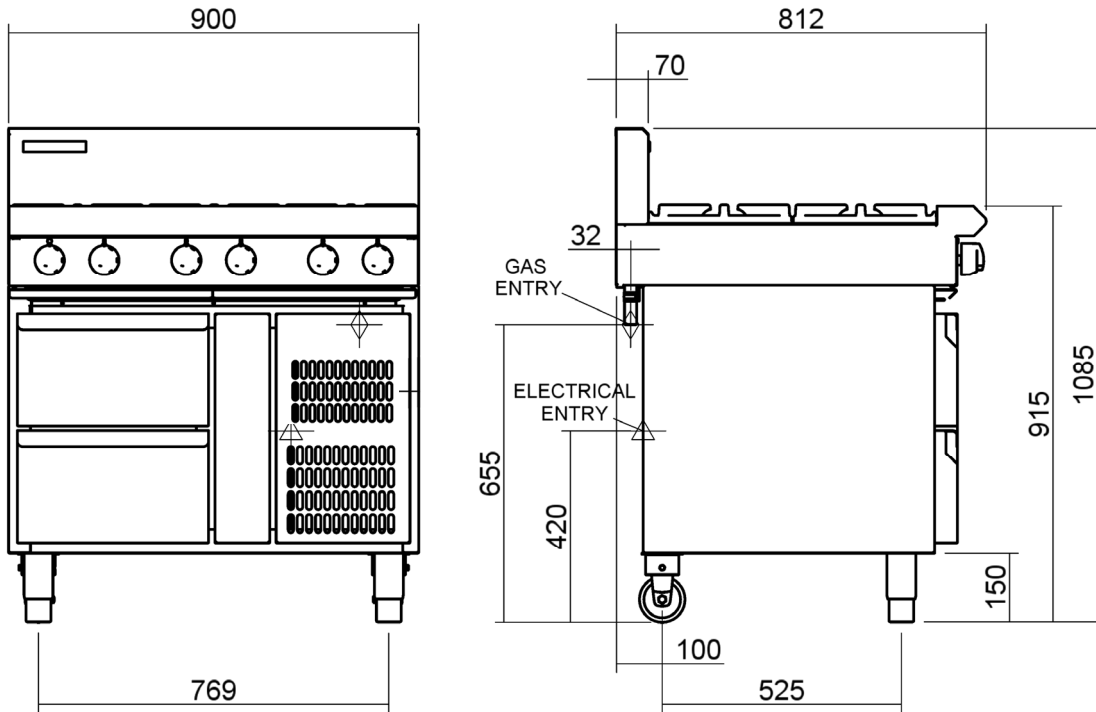

G518-RB

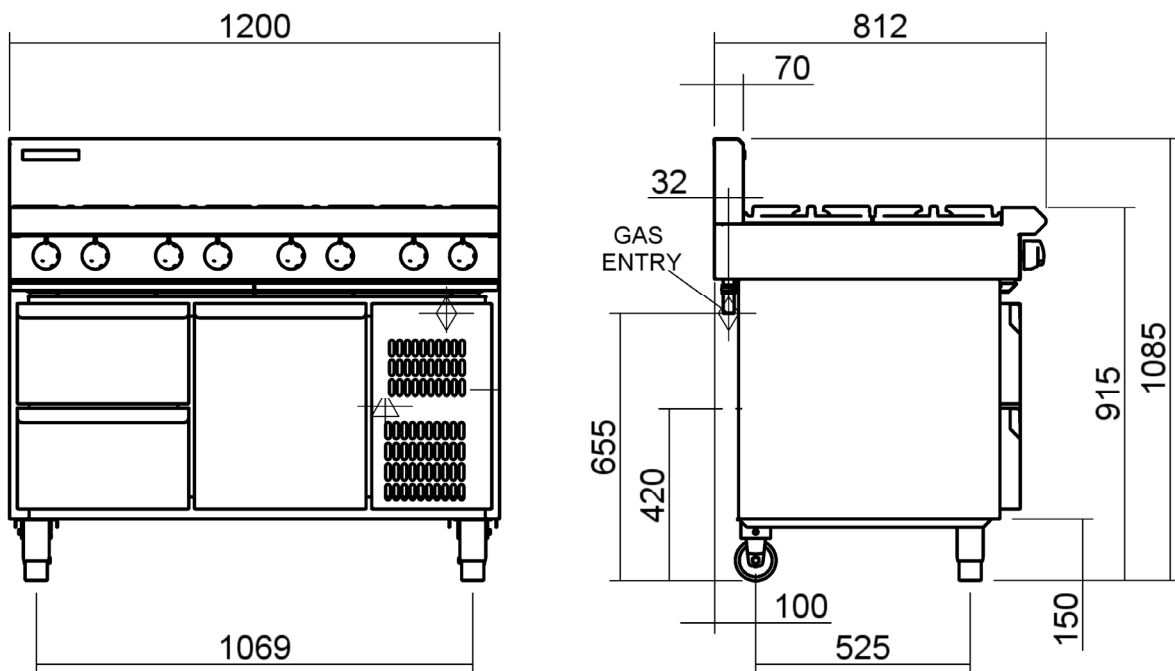

Refer to Page 9 for Cooktop Options

Cooktop Options

G518-D

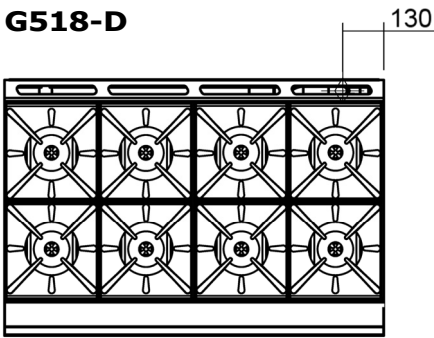

G516-D

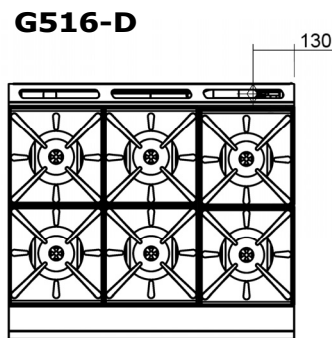

G514-D

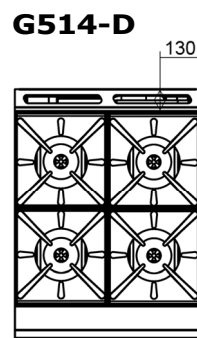

G512-D



G518-C

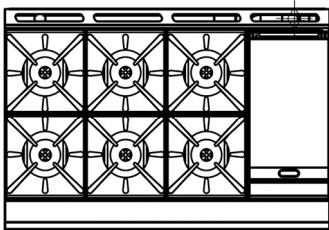

G516-C

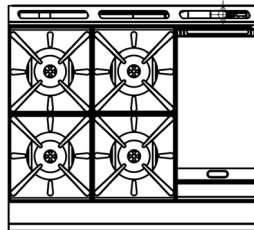

G514-C

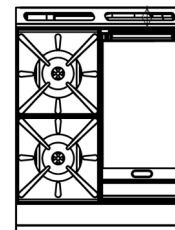

G512-C

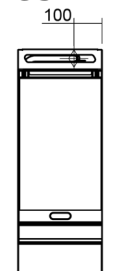

G518-B

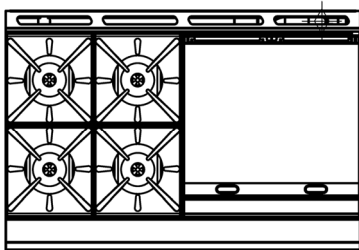

G516-B

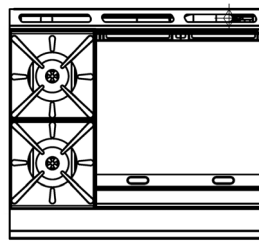

G514-B

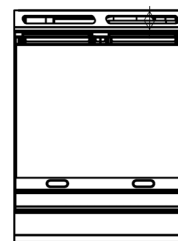

G518-A

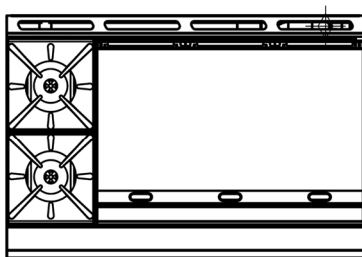

G516-A

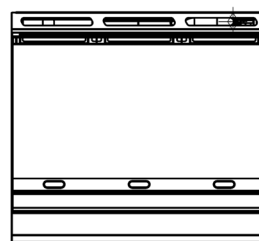

NOTE:

- G512 models are only available in Bench Model (-B) option.
- G514 models are available in Bench Model (-B), Cabinet Base (-CB), or Leg Stand (-LS) model options.
- G516 and G518 models are available in Bench Model (-B), Cabinet Base (-CB), Leg Stand (-LS), or Refrigeration Base (-RB) model options.

For the Refrigeration Cabinet Specifications and Dimensions refer to the Refrigeration Cabinet Installation and Operation Manual supplied with the appliance.

Installation

Installation Requirements

NOTE:

- It is most important that this Cooktop is installed correctly and that operation is correct before use. Installation shall comply with local gas, health and safety requirements.
- This appliance shall be installed with sufficient ventilation to prevent the occurrence of unacceptable concentrations of health harmful substances in the room, the appliance is installed in.

Blue Seal Cooktops are designed to provide years of satisfactory service, and correct installation is essential to achieve the best performance, efficiency and trouble-free operation.

This appliance must be installed in accordance with National installation codes and in addition, in accordance with relevant National / Local codes covering gas and fire safety.

AUSTRALIA:	- AS5601	- Gas Installations.
NEW ZEALAND:	- NZS5261	- Gas Installation.
UNITED KINGDOM:	- Gas Safety (Installation & Use) Regulations 1998.	
	- BS6173	- Installation of Catering Appliances.
	- BS5440 1 & 2	- Installation Flueing & Ventilation.
IRELAND:	- IS 820	- Non - Domestic Gas Installations.

Installations must be carried out by qualified service persons only. Failure to install equipment to the relevant codes and manufacturer's specifications shown in this section will void the warranty.

Components having adjustments protected (e.g. paint sealed) by the manufacturer are only allowed to be adjusted by an authorised service agent. They are not to be adjusted by the installation person.

Unpacking

- Remove all packaging and transit protection from the appliance including all protective plastic coating from the exterior stainless steel panels.
- Check equipment and parts for damage. Report any damage immediately to the carrier and distributor.
- Report any deficiencies to the distributor who supplied the appliance.
- Check that the available gas supply is correct to that shown on the Rating Plate attached to the underside of the R/ H side, front Cooktop lower trim, for Bench, Cabinet Base and Leg Stand Models. For the Refrigerated Base Models the rating plate is located inside the right hand front panel and can be viewed through the upper grille.

Location

1. Installation must allow for a sufficient flow of fresh air for the combustion air supply.

Combustion Air Requirements:				
	G512	G514	G516	G518
Natural Gas (G20)	12m ³ /hr	24m ³ /hr	36m ³ /hr	48m ³ /hr
LPG / Propane (G31)	12m ³ /hr	25m ³ /hr	38m ³ /hr	50m ³ /hr

2. Installation must include adequate ventilation means, to prevent dangerous build up of combustion products.
3. Never directly connect a ventilation system to the appliance flue outlet.
4. Position the appliance in its approximate working position.
5. All air for burner combustion is supplied from underneath the appliance. The legs must always be fitted and no obstructions placed on the underside or around the base of the appliance, as obstructions will cause incorrect operation and / or failure of the appliance.

NOTE: Do not obstruct or block the appliances flue. Never directly connect a ventilation system to the appliance flue outlet.

Clearances

NOTE: Only non-combustible materials can be used in close proximity to this appliance.

	Combustible Surface	Non Combustible Surface
Left / Right hand side	250mm (*)	0mm
Rear	50mm	0mm

* Side clearances can be 50mm when the adjacent surface is at least 100mm below the cooking surface.

Assembly

NOTE:

- All Models are delivered completely assembled. No further assembly is required, with the exception of all Leg Stand Models (G514-LS, G516-LS G518-LS), these will require assembly. Refer to the information below for assembly instructions.
- This appliance is fitted with adjustable feet to enable the appliance to be positioned securely and level. This should be carried out on completion of the gas connection. Refer to the 'Gas Connection' section.

Optional Accessories (Refer to the 'Replacement Parts List' at the rear of this manual)

- Plinth Kit. For installation details, refer to the instructions supplied with each kit.

Bench Models

1. Check that all the feet (and castors) are securely fitted.
2. Adjust the feet to make the Cooktop steady and level.

Fitting the Leg Stand to the Cooktop

WARNING:

TO PREVENT EQUIPMENT DAMAGE AND RISK OF INJURY, REMOVE ALL TRIVETS, BURNER HEADS, GRIDDLE PLATES AND OTHER REMOVABLE ITEMS PRIOR TO FITTING THE LEG STAND.

1. Remove all pot stands, trivets, open burners and griddle plates.
2. Lower the cooktop onto its rear face.
3. Attach the four cooktop legs to the leg mount points on the underside of the cooktop unit.
4. Secure each leg hand tight.
5. Align the 4 round holes in the corners of the base tray with the 4 cooktop legs already fitted. (Ensure that the base tray is orientated with the sloping edge of the base tray facing the front of the appliance).
6. Slot the base tray onto the 4 cooktop legs and push fully home.
7. Secure the base tray to the cooktop legs by screwing the two front adjustable feet supplied, into the base of the front cooktop legs. Secure each adjustable foot, hand tight.
8. The two rear leg housings can be fitted with either adjustable legs or rollers. (See Figure 1).
9. Fit the rear rollers to the rear leg ring plates and secure using the locating bolts supplied, tighten bolts using a 10mm spanner.
10. Lift the cooktop back onto its legs and refit all the items removed at Item 1 above.

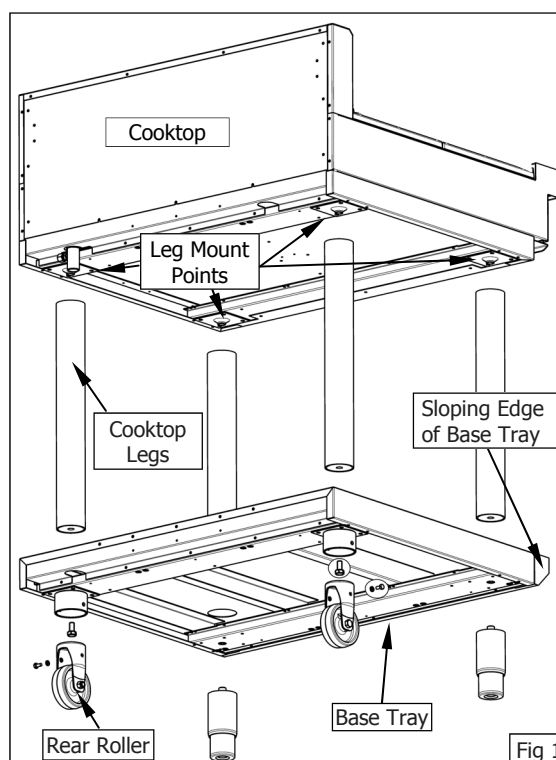

Installation

Gas Connection

NOTE: ALL GAS FITTING MUST ONLY BE CARRIED OUT BY A QUALIFIED PERSON.

1. Blue Seal Cooktops do not require electrical connection, as they function totally on the gas supply.
2. It is essential that the gas supply is correct for the Cooktop to be installed and that adequate supply pressure and volume are available. The following checks should therefore be made before installation:-
 - a. **Gas Type** the appliance has been supplied for is shown on a coloured stickers located above the gas entry point and next to the rating plate. Check that this is correct for the gas supply the appliance is being installed for. The gas conversion procedure is detailed in this manual.
 - b. **Supply Pressure** required for this appliance is shown in the 'Specifications' section of this manual. Check the gas supply to ensure that adequate supply pressure exists.
 - c. **Input Rate** of this appliance is stated on the Rating Plate and in the 'Specifications' section of this manual. The input rate should be checked against the available gas supply line capacity.
Particular note should be taken if the appliance is being added to an existing installation.

NOTE: It is important that adequately sized piping runs directly to the connection joint on the appliance with as few tees and elbows as possible, to give maximum supply volume.

3. Fit the gas regulator supplied, into the gas supply line as close to the appliance as possible.

NOTE: The gas pressure regulator provided with this appliance is convertible between Natural Gas and LPG as per the 'Gas Conversion Section' in this manual.

Ensure the regulator is converted to the correct gas type that the appliance will operate on. The regulator outlet pressure is fixed ex-factory for the gas type that the regulator is converted to and it is NOT to be adjusted.

For G512C-B and G512D-B models, the regulator connection is 1/2" BSP female. The connection on the unit is 1/2" BSP male.

For G514 / G516 / G518 the regulator connections are 3/4" BSP female. The connection on the unit is 3/4" BSP male.

(Refer to the 'Specifications' section for the gas supply location dimensions).

NOTE: A Manual Isolation Valve must be fitted to the individual appliance supply line.

4. Correctly locate the appliance into its final operating position and using a spirit level, adjust the legs so that the appliance is level and at the correct height.
5. Connect the gas supply to the appliance. A suitable joining compound which resists the breakdown action of LPG must be used on every gas line connection, unless compression fittings are used.
6. Check all gas connections for leakages using soapy water or other gas detecting equipment.

WARNING:

DO NOT USE A NAKED FLAME TO CHECK FOR GAS LEAKAGES.

7. Check that the gas operating pressure is as shown in 'Specifications' section.

NOTE: The operating pressure to be measured at the manifold test point and with 2 burners operating at the 'High Flame' setting.

8. Turn off the mains gas supply and bleed the gas out of the appliance gas lines.
9. Turn on the gas supply and the appliance.
10. Verify that the operating pressure remains correct.

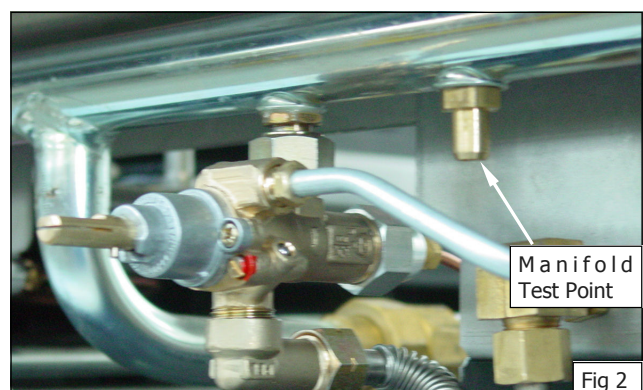

Fig 2

Commissioning

Before leaving the new installation;

Check the following functions in accordance with the operating instructions specified in the 'Operation' section of this manual.

- Lighting the Griddle.
- Light the Open Burners. (F - Option).
- Light the Open Burners. (PF - Option).
- Check the Low Fire burner operation.

Ensure that the operator has been instructed in the areas of correct lighting, operation, and shutdown procedure for the appliance.

This manual must be kept by the owner for future reference and a record of the ***Date of Purchase, Date of Installation*** and ***Serial Number of Appliance*** recorded and kept with this manual. (These details can be found on the Rating Plate;

For Bench, Cabinet Base and Leg Stand Models, the Rating Plate is attached to the underside of the right hand side, front Cooktop lower trim.

For the Refrigerated Base Model, the Rating Plate is located inside the right hand front panel and can be viewed through the upper grille. Refer to the 'Gas Connection' section and the 'Dimensions' section.

NOTE: If for some reason it is not possible to get the appliance to operate correctly, shut off the gas supply and contact the supplier of this appliance.

For the Refrigeration Cabinet Installation details refer to the Refrigeration Cabinet Installation and Operation Manual supplied with the appliance.

Operation

Operation Guide

CAUTION:

- This appliance is for professional use and is only to be used by qualified persons.
- Only authorised service persons are to carry out installation, servicing or gas conversion operations.
- Components having adjustments protected (e.g. paint sealed) by the manufacturer should not be adjusted by the user / operator.

1. Blue Seal appliances have been designed to provide simplicity of operation and 100% safety protection.
2. Improper operation is therefore almost impossible, however bad operation practices can reduce the life of the appliance and produce a poor quality product. To use this appliance correctly please read the following sections carefully:-
 - Lighting the Open Burners (PF Option).
 - Lighting the Open Burners (F Option).
 - Lighting the Griddles.

Description of Controls

NOTE: Only the Cooktop fitted with a 'Griddle Option' and 'Pilot & Flame Failure Option' will have a 'Pilot' position on the Gas Control Knob, the 'Griddle Option' will also have a piezo igniter fitted. The open burner control knobs with 'Flame Failure Option Only' will only have the 'Off', 'Low Flame' and 'High Flame' positions.



Gas Control Knobs

Griddle & Open Burners with 'PF' Option fitted.

Burner Control

- OFF Position
- ★ PILOT Burner
- △ HIGH Flame
- ▽ LOW Flame

Piezo Igniter (Griddles Only)

Open Burner 'F' Option Only

- OFF Position
- △ HIGH Flame
- ▽ LOW Flame
- ▲ Rear Burner
- ▼ Front Burner

(Indicators located above the Gas Control Knobs).

Open Burners ('F' - Flame Failure Option)

Lighting the Open Burners

Flame Failure Protection is incorporated for each burner by way of a thermo-electric system which will shut off the gas supply to that burner in the event that the burner goes out, so that un-burnt gas is not expelled.

- a. Select the burner required, depress and turn the corresponding gas control knob anti-clockwise to the 'HIGH' position.
- b. With the gas control knob depressed, manually light the burner.
- c. Release the gas control knob after approximately 10-20 seconds after lighting the burner.
- d. The burner should stay alight - if not, repeat Steps (a. to (b. above).
- e. To achieve simmer control, depress the gas control knob and rotate between the 'HIGH' and 'LOW' positions to achieve the temperature required.

Turning 'OFF' the Open Burners

- a. When the main burner is not required, depress and turn the gas control knob clockwise back to the 'OFF' position. The 'MAIN' burner will extinguish.

Open Burners ('PF' - Pilot and Flame Failure Option)

Lighting the Open Burners

These hobs are fitted with individual standing pilots for each open burner which allows the main burners to be turned 'ON' - 'OFF' without the need to manually re-light the burner each time that it is turned 'ON', as the burner will automatically light itself off the pilot burner.

Flame Failure Protection is incorporated for each burner by way of a thermo-electric system which will shut off the gas supply to that burner in the event that the burner goes out, so that un-burnt gas is not expelled.

- a. Select the burner required, depress and turn the corresponding gas control knob anti-clockwise to the 'PILOT' position.
- b. With the gas control knob depressed, manually light the pilot burner.
- c. Release the gas control knob after approximately 10-20 seconds after lighting the pilot burner.
- d. The pilot burner should stay alight - if not, repeat Steps (b. to (c. above).
- e. 'Full Flame' can now be achieved by depressing and rotating the gas control knob anti-clockwise to the first stop 'HIGH' flame position.
- f. Low flame can be achieved by depressing the gas control knob and rotating fully anti-clockwise to the 'LOW' flame position.
- g. To achieve simmer control, depress the gas control knob and rotate between the 'HIGH' and 'LOW' positions to achieve the temperature required.

Turning 'OFF' the Open Burners / Pilots

- a. To turn 'OFF' the main burner, but keep the pilot burner alight, rotate the gas control knob to the 'PILOT' position. The main burner will extinguish and the pilot will remain alight.
- b. To turn 'OFF' the 'PILOT', depress and turn the gas control knob clockwise back to the 'OFF' position. The 'PILOT' burner will extinguish.

Operation

Griddle

Lighting the Griddle

- a. Depress the gas control knob and rotate anti-clockwise to the 'PILOT' position.
- b. With the gas control knob depressed, press the piezo ignition button to ignite the pilot burner. Repeat Items 1 to 2 until the pilot is lit.
- c. Release the gas control knob approximately 10-20 seconds after lighting the pilot.
- d. The pilot should now remain alight - if not, repeat Steps (b. to (c. above).
- e. 'Full Flame' can now be achieved by depressing and rotating the gas control knob anti-clockwise to the first stop.
- f. Low flame can be achieved by depressing the gas control knob and rotating fully anti-clockwise to the 'Low Flame' position.
- g. When the main burner is not required, depress and turn the gas control knob clockwise back to the 'OFF' position.

Turning 'OFF' the Griddle Burner / Pilot

- a. To turn 'OFF' the griddle, but keep the pilot burner alight, rotate the gas control knob to the 'PILOT' position. The griddle burner will extinguish and the pilot will remain alight.
- b. To turn 'OFF' the 'PILOT', depress and turn the gas control knob clockwise back to the 'OFF' position. The 'PILOT' burner will extinguish.

IMPORTANT

Should any abnormal operation like;

- ignition problems,
- abnormal burner flame,
- burner control problems,
- partial or full loss of burner flame in normal operation, be noticed, the appliance requires **IMMEDIATE** service by a qualified service person and should not be used until such service is carried out.

Cleaning and Maintenance

CAUTION:

**Always turn off the gas supply before cleaning.
This appliance is not water proof.
Do not use water jet spray to clean interior or exterior of this appliance.**

General

Clean the Cooktop regularly. A clean Cooktop looks better, will last longer and will perform better. Carbonised grease on the surface or between the trivets, griddle plates will hinder the transfer of heat from the cooking surface to the food. This will result in loss of cooking efficiency.

NOTE: Each griddle option can be supplied with a scraper tool and a pack of blades for cleaning the griddle surface. These are not supplied with the griddle and have to be purchased separately. Refer to the 'Replacement Parts List' at the rear of this manual.

WARNING:

THE BLADES FITTED TO THE SCRAPER TOOL ARE EXTREMELY SHARP AND ARE TO BE USED WITH CARE.

DO NOT use water on the trivets, burners and griddle plates while these items are still hot as warping and cracking may occur. Allow these items to cool down and then remove for cleaning. The entire trivets, griddle plates and burner caps can be dismantled for cleaning.

NOTE:

- **DO NOT use abrasive detergents, strong solvents or caustic detergents as they could corrode or damage the Cooktop.**
- **In order to prevent the forming of rust on the trivets, griddle plate (If fitted), and burners, ensure that any detergent or cleaning material has been completely removed after each cleaning. The appliance should be switched on briefly to ensure the griddle plates become dry. Oil or grease should be spread over the griddle surface in order to form a thin protective greasy film.**

To keep your Cooktop clean and operating at peak efficiency, follow the procedures shown below:-

After Each Use

CAUTION:

Always ensure that an even pressure is applied over the whole surface of the scraper tool when using on the flat surface of the griddle, to prevent scoring of the surface.

NEVER bang the sharp edge of the scraper tool on the flat surface of the griddle as this will damage the griddle and invalidate the warranty.

1. Clean the griddle and Cooktop castings with a scraper tool to remove any build up of carbon.
2. Always ensure that the scraper tool blades are changed regularly to ensure that the scraper tool works efficiently and prevents damage to the griddle plate surface.
3. Clean the range castings with a stiff nylon brush or a flexible spatula to remove any food debris.

Cleaning and Maintenance

Daily Cleaning

1. The spill tray(s) should be checked and emptied frequently to prevent overflow and spillage. Remove the spill tray(s) while still warm so that the grease is in a liquid state. Empty any grease from the trays and wash thoroughly in the same manner as any cooking utensil.
2. Remove the burner caps and bases, the trivets and thoroughly clean the splash back, interior and exterior surfaces of the range with hot water, a detergent solution and a soft scrubbing brush.
3. Brush the griddle surface (optional - if fitted) with a soft bristled brush. Any carbon deposits should be removed using a scraper tool followed by wiping with a cloth to prevent accumulation of food deposits.
4. Dry the Cooktop thoroughly with a dry cloth and polish with a soft dry cloth.

Weekly Cleaning

NOTE:

- If the Cooktop usage is very high, we recommend that the weekly cleaning procedure is carried out on a more frequent basis.
- Ensure that protective gloves are worn during the cleaning process.
- DO NOT use harsh abrasive detergents, strong solvents or caustic detergents as they will damage the Cooktop and burners and griddle plates (if fitted).
- DO NOT use water on the trivets, griddle plates and burners while they are still hot as cracking may occur. Allow these items castings to cool and remove for cleaning.
- DO NOT clean the burners in a dishwasher.

Cooktop Cooking Area

- a. Clean the Cooktop cooking area using a soft cloth moistened with a mild detergent and hot water solution.
- b. Baked on deposits or discolouration may require a good quality stainless steel cleaner or stainless steel wool. Always apply cleaner when the appliance is cold and rub in the direction of the grain.
- c. It should not be necessary to remove the splash guards covering the burner manifolds for cleaning purposes. These can be cleaned in situ.
- d. Remove the spill tray(s) and clean with a mild anti bacterial detergent and hot water solution using a soft bristled brush. Dry the grease spill tray(s) thoroughly with a dry cloth.

Griddle Plate (Steel)

CAUTION:

Always ensure that an even pressure is applied over the whole surface of the scraper tool when using on the flat surface of the griddle, to prevent scoring of the surface.

NEVER bang the sharp edge of the scraper tool on the flat surface of the griddle as this will damage the griddle and invalidate the warranty.

NOTE: In order to prevent the forming of rust on the griddle plate, ensure that all detergent and cleaning material has been entirely removed after each cleaning process. The appliance should be switched on briefly to ensure the griddle plate becomes dry. Oil or grease should be spread over the griddle surface in order to form a thin protective greasy film.

- a. Remove and clean the spill tray(s) frequently to prevent over spills.
- b. Clean the griddle surface thoroughly with a scraper tool or a wire brush. If necessary use a griddle stone or a scotch bright pad on the griddle surface to remove stubborn or accumulated carbon deposits.
- c. Occasionally bleach the griddle plate with vinegar when the plate is cold.
- d. Clean with hot water, a mild detergent solution and a scrubbing brush. Dry all components thoroughly with a dry cloth.
- e. The Cooktop should be switched on briefly to ensure that the griddle plate becomes dry. A thin smear of cooking oil should be spread over the grates in order to form a protective film.

Trivets and Burners

- Remove the trivets from the top of the appliance, taking note that the trivets are manufactured with a lip on one edge, the lip must always be fitted to the outer edge (front and back) of the Cooktop. (Refer to Fig 8 overleaf).
- Remove the burner cap and burner bowl (these are a loose fit to the manifold, see Fig 4) from the top of the gas manifold, taking care not to damage the thermocouple fitted through the manifold splash guard. (Refer to Fig 7).
- The trivets and burners should be cleaned with a mild detergent and hot water solution using a soft bristled brush. Dry thoroughly with a dry cloth.

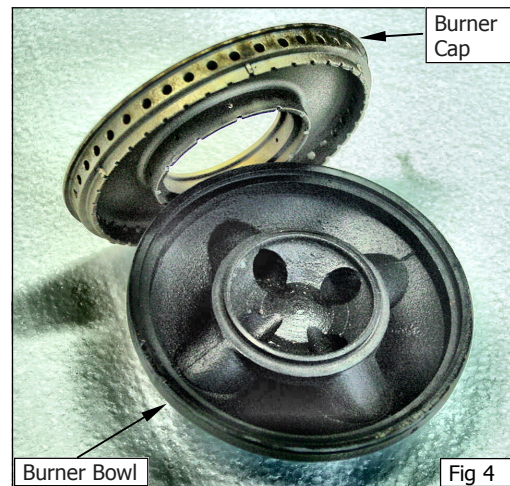

Trivet Supports

- Remove all the trivet supports from the top of the appliance. Take note of the orientation of the trivet support when removing. The trivet support front end side rail profiles are different from the rear end side rail profiles. (See the Note shown at Item a in 'Re-Fitting the Components to the Cooktop' below and Figure 5 opposite).
- The trivet supports should be cleaned with a mild detergent and hot water solution using a soft bristled brush.
- Dry the trivet supports thoroughly with a dry cloth.

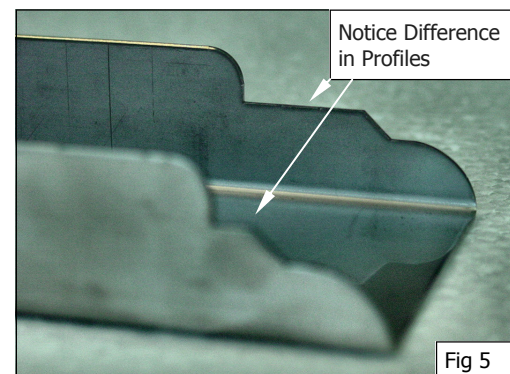

Stainless Steel Surfaces

- With the griddle plates and burners removed, clean the interior and exterior surfaces of the Cooktop with hot water, a mild detergent solution and a soft scrubbing brush. Note that the gas control knobs are a push fit onto the gas control valve spindles and can be removed to allow cleaning of the front of the control panel.
- Baked on deposits or discolouration may require a good quality stainless steel cleaner or stainless steel wool. Always apply cleaner when the appliance is cold and rub in the direction of the grain.
- It should not be necessary to remove the splash guards covering the burner manifolds for cleaning purposes. These can be cleaned in situ.
- Dry all components thoroughly with a dry cloth and polish with a soft dry cloth.
- To remove any discolouration, use an approved stainless steel cleaner or stainless steel wool. Always rub in the direction of the grain.
- Remove the grease tray and clean with a mild anti bacterial detergent and hot water solution using a soft bristled brush.
- Dry the grease tray thoroughly with a dry cloth.

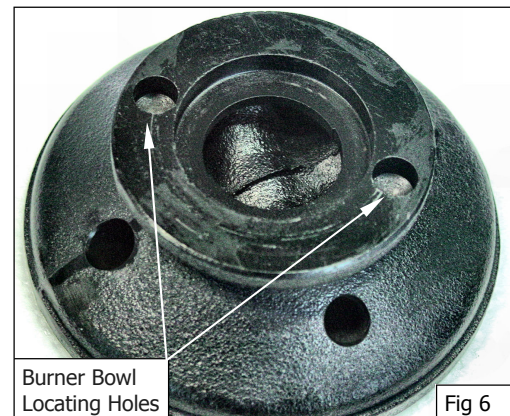

Re-Fitting the Components to the Cooktop

- Refit the trivet supports to the Cooktop, ensuring that the trivet supports are correctly fitted.

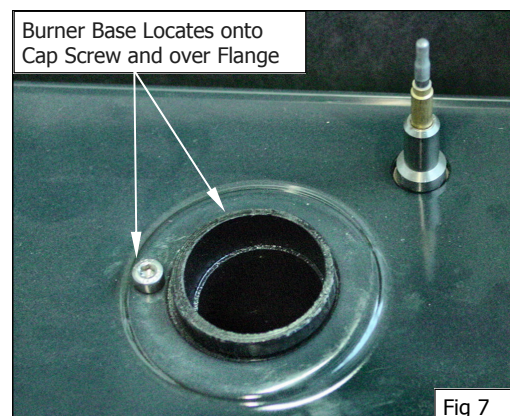

Cleaning and Maintenance

NOTE: It is imperative that the trivet supports are correctly re-fitted to the appliance to ensure that the trivets locate correctly and sit flush and level. NOTE that the trivet support front end, side rail profiles are different at either side and only one of the side rails seat into the cut-out in the Cooktop. where as the rear end of the trivet support side rail profiles are the same and have 2 cut-outs to locate into.

- b. Refit the burner bowls onto the manifolds protruding through the splash guards, taking care not to damage the thermocouple which is close to the manifold.

NOTE: The burner bowl has 2 locating holes drilled into the base flange, these are to locate the burner bowl to the cap screw on the gas manifold when re-fitting the burner bowl onto the gas manifold (Refer to Figs 6 & 7 on the previous page).

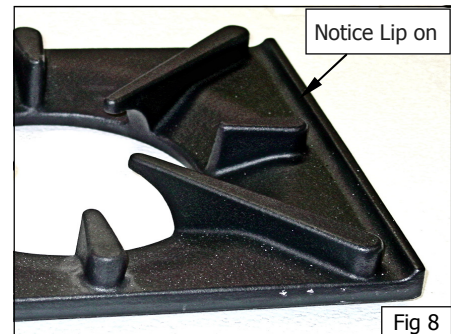

- c. Refit the burner caps (cast brass) onto the burner bowls already fitted to the manifold. These are a loose fit into the burner bowls.
- d. Refit the trivets to the top of the appliance, taking note that the trivets are manufactured with a lip on one edge, the lip must always be fitted to the outer edge (front and back) of the Cooktop. (Refer to Fig 8).
- e. Refit the grease tray to the Cooktop.

Periodic Maintenance

NOTE: All maintenance operations should only be carried out by a qualified service person.

To achieve the best results, cleaning must be regular, thorough and all controls and mechanical parts should be checked and adjusted periodically by a qualified service person. If any small faults occur, have them attended to promptly. Don't wait until they cause a complete breakdown. It is recommended that the appliance is serviced every 6 months.

Gas Control Valve Re-Greasing

The gas control valve should be dismantled and greased every 6 months to ensure the correct operation of the gas control valve.

To carry out this operation;-

- a. Remove the gas control knobs from the gas tap spindles by pulling the knobs away from the control panel.
- b. Remove the drip tray from the appliance.
- c. Remove the two screws on the underside of the control panel, securing the control panel to the hob.
- d. Remove the control panel from the front of the appliance.
- e. Remove the 2 screws holding shaft plate to gas control body and remove control shaft and plate. (Refer to Fig 9). Note orientation of shaft for correct re-assembly.
- f. Using needle nose pliers or similar, pull out gas control spindle, again noting its orientation.
- g. Apply a suitable high temperature gas cock grease or lubricant such as Rocol - A.S.P (Anti scuffing paste) / Dry Moly Paste to the outside of the spindle. (Refer to Fig 10).
- h. Replace spindle and re-assemble the gas control in reverse order.
- i. Refit the control panel to the appliance and secure with 2 screws.
- j. Refit the knobs to the gas control valve spindles.

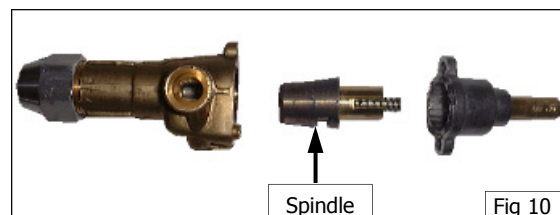
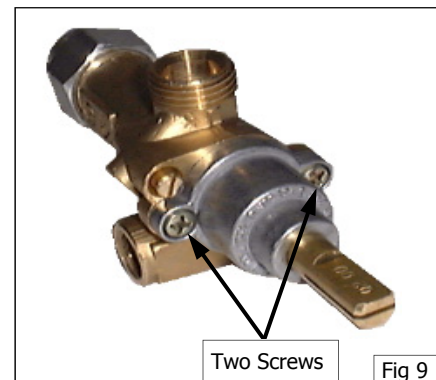

For the Refrigeration Cabinet Cleaning and Maintenance refer to the Refrigeration Cabinet Installation and Operation Manual supplied with the appliance.

Fault Finding

This section provides an easy reference guide to the more common problems that may occur during the operation of your equipment. The fault finding guide in this section is intended to help you correct, or at least accurately diagnose problems with your equipment.

Although this section covers the most common problems reported, you may encounter a problem not covered in this section. In such instances, please contact your local authorised service agent who will make every effort to help you identify and resolve the problem. Please note that the service agent will require the following information:-

- **Model Code and the Serial Number of the appliance. (Both can be found on the Rating Plate located on the appliance).**

Fault	Possible Cause	Remedy
Pilot won't light.	No gas supply. Blocked pilot injector. (Griddle Option Only).	Ensure gas isolation valve is turned on, and that bottles are not empty. Call the service provider.
Pilot goes out when gas control knob released. (Griddle and Open Burner (PF) options only).	Releasing knob before the thermocouple has heated. Pilot flame too small. - Gas pressure too low. - Partially blocked pilot injector. Thermocouple connection to the gas control is loose or faulty. Thermocouple faulty. Electromagnet in the rear of the gas control unit is faulty.	Hold knob in for at least 20 seconds following ignition of the pilot. Clean or replace the pilot injector. Tighten the thermocouple connection. Check that the thermo couple is producing between 20-30mV. Inspect and replace if not in good working order. Call the service provider.
Main burner will not light.	Incorrect supply pressure. Faulty gas control.	Call the service provider. Call the service provider.
Piezo Ignition spark is being generated but not sparking from the ignition electrode to the pilot burner hood. (Griddle Option Only)	HT lead damaged or broken. Check that the ignition electrode is not cracked and is correctly positioned. Piezo igniter faulty.	Repair or replace the HT lead. Re-position or replace the ignition electrode. Replace the piezo igniter. Call the service provider.

NOTE: Components having adjustments protected (e.g. paint sealed) by the manufacturer, are only to be adjusted by an authorised service agent. They are not to be adjusted by an unauthorised service person.

For the Refrigeration Cabinet Fault Finding refer to the Refrigeration Cabinet Installation and Operation Manual supplied with the appliance.

Gas Conversion and Specifications

Conversion Procedure

CAUTION:

Ensure that the Appliance is isolated from the gas supply before commencing servicing.

NOTE:

- These conversions should only be carried out by qualified persons. All connections must be checked for leaks before re-commissioning the appliance.
- Adjustment of components that have adjustments / settings sealed (e.g. paint sealed) can only be adjusted in accordance with the following instructions and shall be re-sealed before re-commissioning this appliance.
- For all relevant gas specifications refer to the table at the end of this section.

Open Burners ('F' - Flame Failure Option)

1. Turn 'OFF' the gas supply at the main supply.
2. Remove the trivets from the top of the appliance, taking note that the trivets are manufactured with a lip on one edge, the lip must always be fitted to the outer edge (front and back) of the Cooktop.
3. Remove the burner caps and burner bowls (these are a loose fit to the manifold) from the top of the gas manifold, taking care not to damage the thermocouples fitted through the manifold splash guard.
4. Remove all the trivet supports from the top of the appliance. Note the orientation of the trivet supports when removing. The trivet support front end side rail profiles are different from the rear end side rail profiles.
5. Remove the splash guards covering the burner manifolds by unscrewing the two allen headed screws. Carefully remove the splash guards taking care not to damage the thermocouples protruding through the splash guard.
6. Unscrew and remove the injectors ($\frac{1}{2}$ " A/F) from the gas cocks.
7. Determine the correct injector sizes for the corresponding gas from the rating plate.
 - **For Bench, Cabinet Base and Leg Stand Models**, the Rating Plate is attached to the underside of the right hand side, front Cooktop lower trim.
 - **For the Refrigerated Base Model**, the Rating Plate is located inside the right hand front panel and can be viewed through the upper grille. Refer to the 'Gas Connection' section and the 'Dimensions' section.
8. Replace with the correct size injectors. Refer to the 'Gas Specifications table' at the end of this section, for correct injector sizes.
9. Refit the splash guards over the gas cocks taking care not to damage the thermocouples and secure in position with the 2 allen headed screws. (Refer to Fig 13).
10. Refit the burner caps and burner bowls onto the manifolds protruding through the splash guards, taking care not to damage the thermocouple which is close to the manifold. Take note that the base part of the burner bowl has 2 locating holes drilled into the base flange (Refer to Fig 14), these are to locate the burner bowl onto the allen headed screws that secure the splash guard to the gas manifold.

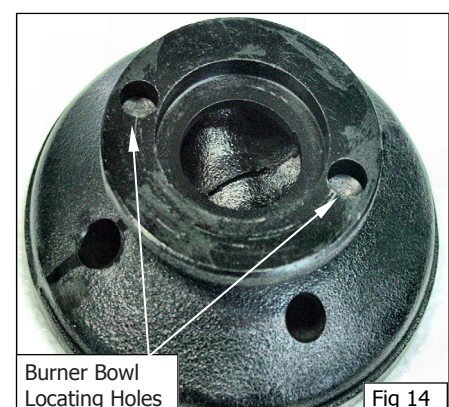
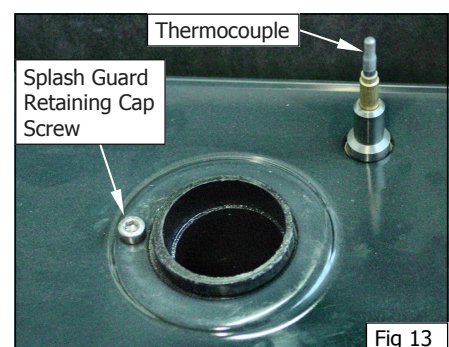
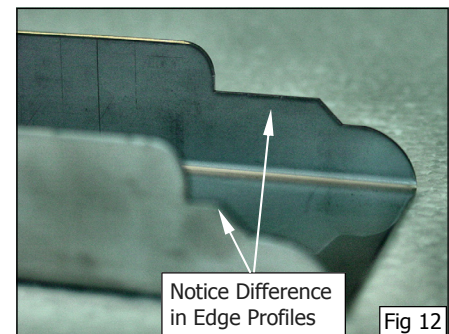
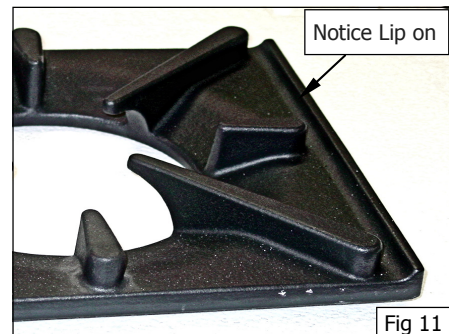

Gas Conversion and Specifications

11. Refit all the trivet supports to the top of the appliance. Note the orientation of the trivet support when re-fitting as the front end side rail profiles are different from the rear end side rail profiles. (Refer to Fig 12).
12. Refit the trivets to the top of the appliance taking note that the trivets are manufactured with a lip on one edge, the lip must always be fitted to the outer edge (front and back) of the Cooktop. (Refer to Fig 11 on previous page).
13. Turn on the gas supply at the mains, re-light the burners and check the flame size on the simmer (LOW) position.

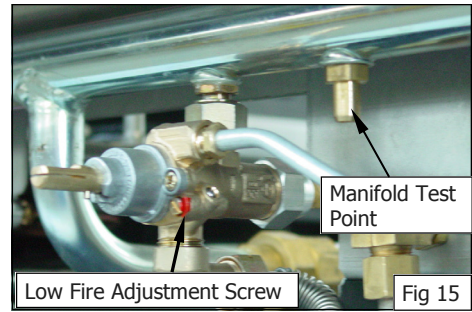

NOTE: The right hand gas control valve supplies the rear burner and the left hand gas control valve supplies the front burner.

Low Fire Adjustment

- a. To adjust the open burner low fire adjustment, remove the gas control knobs from the front of the control panel.
- b. Adjust the low fire adjustment screw on the open burner gas control valves to obtain the desired flame size. (Refer to Fig 15).

NOTE: The 'Low Fire Screw' should be sealed with coloured paint on completion of the low fire adjustment.

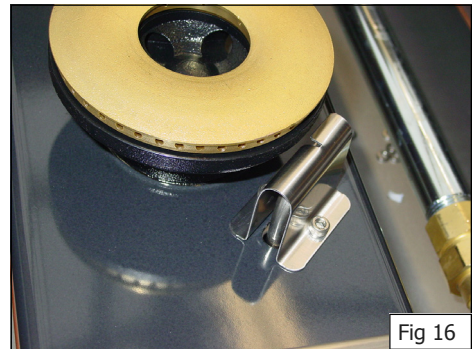

Open Burners ('PF' - Pilot & Flame Failure Option)

1. Turn 'OFF' the gas supply at the main supply.
2. Remove the trivets from the top of the appliance, taking note that the trivets are manufactured with a lip on one edge, the lip must always be fitted to the outer edge (front and back) of the Cooktop. (Refer to Fig 11).
3. Remove the burner caps and burner bowls (these are a loose fit to the manifold) from the top of the gas manifold, taking care not to damage the thermocouples and pilot burners fitted through the manifold splash guard.
4. Remove all the trivet supports from the top of the appliance. Note the orientation of the trivet supports when removing. The trivet support front end side rail profiles are different from the rear end side rail profiles. (Refer to Fig 12).
5. Remove the pilot burner shields from over the pilot burners / thermocouples by removing the 2 screws securing the pilot burner shields to the splash guards. (Refer to Fig 17).
6. Remove the splash guards covering the burner manifolds by unscrewing the two allen headed screws. Carefully remove the splash guards taking care not to damage the pilot burners and thermocouples protruding through the splash guard.

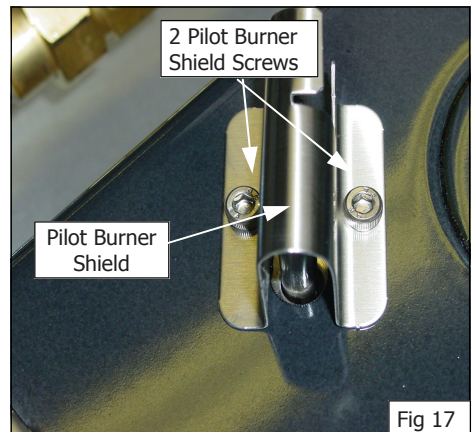

Main Injectors

- a. Unscrew and remove the main injectors (1/2" A/F) from the gas cocks.
- b. Replace with the correct size injectors. Refer to the 'Gas Specifications Table' at the end of this section and the Rating Plate for correct injector sizes for the corresponding gas.
 - **For Bench, Cabinet Base and Leg Stand Models,** the Rating Plate is attached to the underside of the right hand side, front Cooktop lower trim.

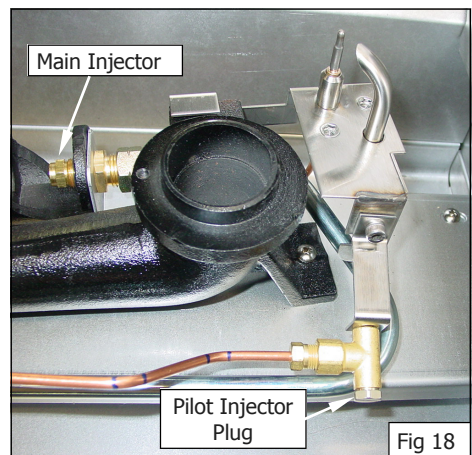

Gas Conversion and Specifications

- **For the Refrigerated Base Model**, the Rating Plate is located inside the right hand front panel and can be viewed through the upper grille. Refer to the 'Gas Connection' section and the 'Dimensions' section.

Pilot Injectors

- Unscrew and remove the Pilot Injector Plug from the fitting at the end of the pilot injector tube using a 11mm A/F spanner.
- Using a flat bladed screwdriver, unscrew and remove the pilot injector from the pilot injector housing.

NOTE Take care not to lose the spring fitted in front of the injector.

- Remove existing pilot injector and replace with the correct size pilot injector for the gas type being used. Refer to the 'Gas Specifications' table at the end of this section, for correct pilot injector sizes.
- Refit the spring and the correct pilot injector to the pilot injector housing.
- Screw the pilot injector fully home using a flat blade screwdriver and refit the pilot injector plug to the pilot injector housing and tighten in place using a 11mm A/F spanner. (Refer to Fig 19).
- Refit the splash guard over the gas cocks taking care not to damage the thermocouples and pilot burners and secure in position with the 2 allen headed screws. (Note that the splash guard for 'FP' models has a different cut-outs for pilot burner. Refer to Fig 20).
- Refit the pilot burner shield over the pilot burners / thermocouples and secure in place with the 2 securing screws. (Refer to Fig 17).
- Refit the burner caps and burner bowls onto the manifolds protruding through the splash guards. Take note that the base part of the burner bowl has 2 locating holes drilled into the base flange, these are to locate the burner bowl onto the allen headed screws that secure the splash guard to the gas manifold.
- Refit all the trivet supports to the top of the appliance. Note the orientation of the trivet support when re-fitting as the front end side rail profiles are different from the rear end side rail profiles. (Refer to Fig 12).
- Refit the trivets to the top of the appliance taking note that the trivets are manufactured with a lip on one edge, the lip must always be fitted to the outer edge (front and back) of the Cooktop. (Refer to Fig 11).

Low Fire Adjustment

- To adjust the open burner low fire adjustment, remove the gas control knobs from the front of the control panel.
- Adjust the low fire adjustment screw on the open burner gas control valves to obtain the desired flame size. (Refer to Fig 22).

NOTE: The 'Low Fire Screw' should be sealed with coloured paint on completion of the low fire adjustment.

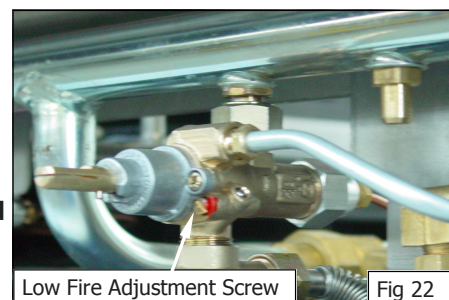
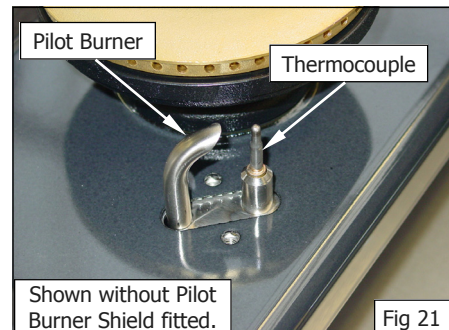
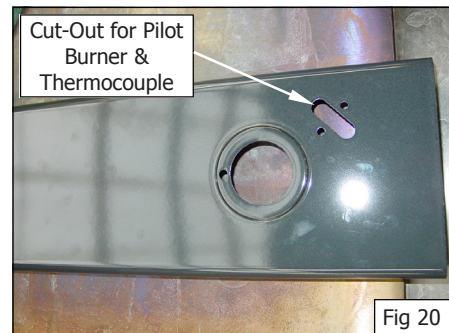
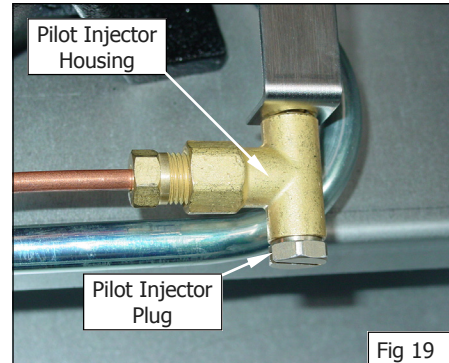

Griddles

Pilot Burner

- With the gas supply turned off at the main supply, remove the griddle plate section by lifting it straight off the Cooktop.
- Remove the gas control heat shield from around the griddle burner, this is just a push-in fit.
- Disconnect the piezo igniter from the mounting bracket. (For access purposes).
- Disconnect the pilot supply tube from the pilot burner with a 13mm (1/2") spanner.
- Remove existing pilot injector and replace with the correct size for the gas being used. Refer to the 'Gas Specifications' table at the end of this section, for correct injector sizes.
- Re-connect the pilot supply tube to the pilot burner with a 13mm (1/2") spanner.
- Refit the piezo igniter to the mounting bracket.

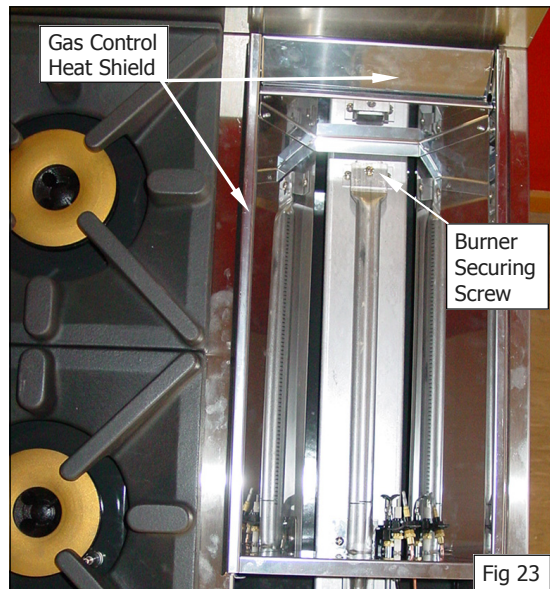

Main Burner

- Remove the main burner from the burner box by removing the securing screw at the end of the burner, this will reveal the main burner injector.
- Remove and replace the main burner injectors with correct size injectors. Refer to the 'Gas Specifications' table at the end of this section, for correct injector sizes.
- Refit the burner to the griddle burner box.
- Refit the gas control heat shield to the griddle burner box.
- Refit the griddle plate section to the top of the Cooktop.
- Repeat Items (a, to (e, for all griddle main burners.
- Turn 'ON' the gas supply at the mains, re-light the griddle burners and check the flame size on the 'LOW' flame position.

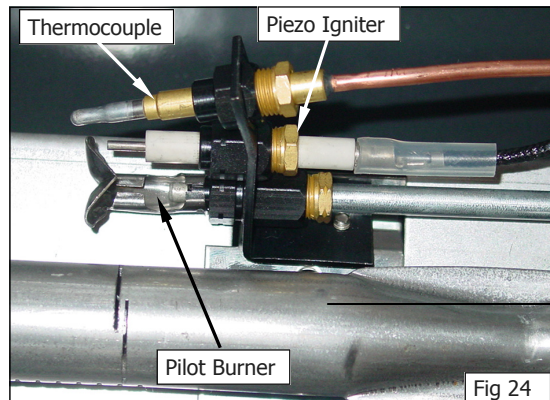

Low Fire Adjustment

- To adjust the griddle burner 'LOW' fire adjustment, remove the griddle gas control knobs from the front of the control panel.
- Adjust the low fire adjustment screw on the griddle gas control valve only, to obtain the desired flame size.

NOTE: The 'Low Fire Screw' should be sealed with coloured paint on completion of the low fire adjustment.

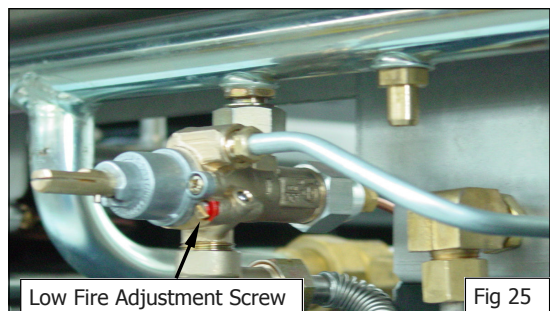

Gas Conversion and Specifications

Commissioning

Before leaving the converted installation;

1. Check all gas connections for leakages using soapy water or other gas detecting equipment.

WARNING:

DO NOT USE A NAKED FLAME TO CHECK FOR GAS LEAKAGES.

2. Check the following functions in accordance with the operating instructions specified in the 'Operation' section of this manual.
 - Light the Pilot Burners.
 - Light the Main Burners.
 - Check the Low Fire Burner operation.
 - Check the High Fire Burner operation.
 - Ensure that all the controls operate correctly.
 - Ensure that the operating pressure remains correct.
3. Ensure any adjustments done to components that have the adjustments / settings sealed (e.g. paint sealed) are re-sealed.
4. This manual must be kept by the owner for future reference and a record of ***Date of Purchase, Date of Installation*** and ***Serial Number of Appliance*** should be recorded and kept with this manual. (These details can be found on the Rating Plate attached to the underside of the R/H side, front Cooktop lower trim, for Bench, Cabinet Base and Leg Stand Models. For the Refrigerated Base Models, the Rating Plate is located inside the right hand front panel and can be viewed through the upper grille. Refer to the 'Gas Connection' section).

NOTE: If for some reason it is not possible to get the appliance to operate correctly, shut off the gas supply and contact the supplier of this appliance.

Gas Specifications

- Australia / New Zealand Only:

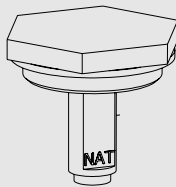
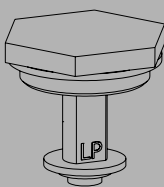
		Natural. Gas (G20)	Propane (G31)
Open Burner	Main Burner	Ø 2.45 mm	Ø 1.50 mm
	Pilot Burner ('PF' Models only)	0.30	0.20
Griddle	Main Burner	Ø 2.10 mm	Ø 1.30 mm
	Pilot Burner	0.35	0.23
	Burner Aeration Setting	Fully open	Fully open
Supply Pressure		1.13 - 3-40 kPa	2.75 - 3-40 kPa
Operating Pressure		0.95 kPa (*)	2.6 kPa (*)
Gas Regulator Cap Screw			

Specifications

- UK Only:

Appliance Classification

Category: **II_{2H3P} (20, 30 / 37).**

Flue Type: **A₁.**

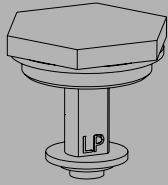
		Natural. Gas (G20)	Propane (G31)
Open Burner	Main Burner Injectors	Ø 2.30 mm	Ø 1.40 mm
	Pilot Burner ('PF' Models only)	0.30	0.20
Griddle	Main Burner	Ø 2.10 mm	Ø 1.30 mm
	Pilot Burner	0.35	0.23
	Burner Aeration Setting	Fully open	Fully open
Supply Pressure		20 mbar	30 / 37 mbar
Operating Pressure		9.5 mbar (*)	26 mbar (*)
Gas Regulator Cap Screw			

* - The burner operating pressure is to be measured at the manifold test point with two burners operating at full setting. The operating pressure is ex-factory set, through the appliance regulator and is not to be adjusted, apart from when carrying out gas conversion, if required. (Refer to the 'Gas Conversion' section for details).

Replacement Parts List

IMPORTANT:

Only genuine authorized replacement parts should be used for the servicing and repair of this appliance. The instructions supplied with the parts should be followed when replacing components.

For further information and servicing instructions, contact your nearest authorized service branch (contact details are as shown on the reverse of the front cover of this manual).

When ordering replacement parts, please quote the part number and the description as listed below. If the part required is not listed below, request the part by description and quote model number and serial number which is shown on the rating plate.

Open Burners

227018	Burner Bowl.			
227017	Burner Cap.			
030245	Injector	(Nat. Gas)	Ø 2.45 mm.	
030230	Injector	(Nat. Gas)	Ø 2.30 mm	(UK Only).
030150	Injector	(LP Gas [Propane])	Ø 1.50 mm.	
030140	Injector	(LP Gas [Propane])	Ø 1.40 mm	(UK Only).
026134	Pilot Injector	(Nat Gas)	0.30	(PF Option).
026136	Pilot Injector	(LP Gas [Propane])	0.20	(PF Option).
229442	Pilot Bracket Assembly			(PF Option).
229444	Pilot Burner Shield			(PF Option).
227405	Gas Control			(F Option).
227403	Gas Control			(PF Option).
227378	Knob - Open Burner			(PF Option).
227379	Knob - Open Burner			(F Option).
228167	Thermocouple - Front.			
228166	Thermocouple - Rear.			

Griddle

014105	Burner.			
032210	Injector	(Nat. Gas)	Ø 2.10 mm.	
032130	Injector	(LP Gas [Propane])	Ø 1.30 mm.	
227403	Gas Control	(with Flame Failure and Pilot).		
227378	Knob - Griddle.			
019215K	Pilot Burner Kit.			
026488	Pilot Orifice	(Nat. Gas)	0.35.	
019217	Pilot Orifice	(LP Gas [Propane])	0.23.	
019428	Thermocouple.			
227508	Piezo Ignitor.			
228047	Piezo H.T. Lead.			
018744	Piezo Ignition Electrode.			
228288	Grease Tray	(Griddle Plates).		

Replacement Parts List

General

227014	Pot Stand / Trivet.	
230286	Spill Tray	(G512 Series).
230277	Spill Tray	(G514 / G518 Series).
230273	Spill Tray	(G516 Series).
227855	Adjustable Legs	(84 mm - Bench Models).
227850	Adjustable Legs (Flush Stud)	(150 mm - CB / RB Models).
227851	Adjustable Legs (Extd stud)	(150 mm LS Models).
229674	Rear Roller Assy.	
232351	Rear Roller Assy 3"	(Refrigeration Base).

Optional Extras

228566	Griddle Scraper Tool.	
228567	Smooth Plate Scraper Blades	(Pack of 5 Blades).
228568	Ribbed Plate Scraper Blade	(Individual Blade).

Regulators

Gas Type	Model	Gas Regulators	
		Part No.	Description
Nat. Gas LPG / Propane	G512	228533	½" BSP F/F Convertible.
	G514	228531	¾" BSP F/F Convertible.
	G516		
	G518		

Gas Conversion Kits

Models		Gas Type to Convert to			
		UK Only		Australia / New Zealand Only	
		Nat. Gas	LPG (Propane)	Nat. Gas	LPG
'F' Models	G512	231869	231868	231837	231836
	G514	231871	231870	231841	231840
	G516	231873	231872	231845	231844
	G518	231875	231874	231849	231848
'PF' Models	G512	231877	231876	231853	231852
	G514	231879	231878	231857	231856
	G516	231881	231880	231861	231860
	G518	231883	231882	231865	231864

Accessories

228795	600 mm Plinth Kit.
228799	900 mm Plinth Kit.
228803	1200 mm Plinth Kit.

For the Refrigeration Cabinet Replacement Parts information refer to the Refrigeration Cabinet Installation and Operation Manual supplied with the appliance.

