

Built-in product stops facilitate angled product display

Retractable night blind reduces off-peak energy consumption

Illuminated lightbox increases brand presence

Transparent side glass extends product visibility

Adjustable shelving for flexibility in display configuration

High-impact, full-height LED lighting for perfect product presentation

Invisible air curtain maintains temperature and enables open access to products

Plastic bumpers provide protection from accidental damage

Plug-in design offers flexible unit placement and simplifies installation

Corrosion-resistant construction ensures longevity

Allows display of delicate produce

Castors for easy placement & movement



Bromic's Open Display range offers powerful performance in a plug-in package, creating attractive open displays with exceptionally accurate temperature control.

61. Vision ECO Displays

Bromic's Vision ECO Open Displays have been developed in partnership with internationally-acclaimed manufacturer IARP to offer plug-in solutions that simplify the installation of self-service refrigerated retail aisles.

Accurate temperature controls allow this unit to display delicate produce despite its open front while plug-in operation eliminates the need for prior planning approval and an expensive installation.



62. Specification Reference Guide

PROFESSIONAL RANGE

OPEN DISPLAYS

Open Displays

PROFESSIONAL RANGE

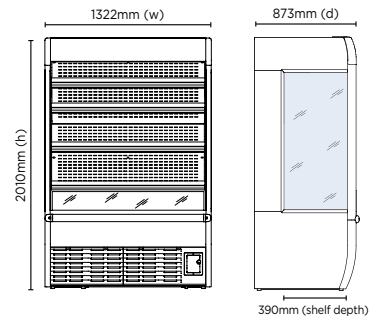

VISION1200



Vision ECO 1330L LED Open Display

Part No.	Capacity	Weight
3335274	1330L	266kg

External (mm)	
Width	1322
Depth	873
Height	2010

- Invisible air curtain maintains temperature
- Adjustable tilt shelves with built-in product stops for easy display set-up
- Included night blind reduces energy consumption during off-peak periods
- Temperature range: 0 to +10°C

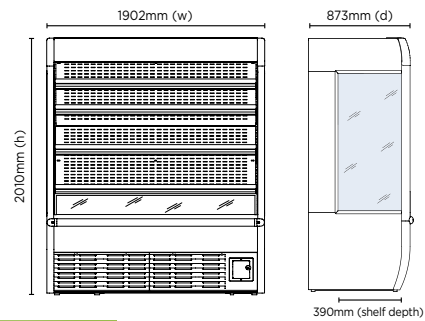

VISION1800



Vision ECO 1913L LED Open Display

Part No.	Capacity	Weight
3335276	1913L	310kg

External (mm)	
Width	1902
Depth	873
Height	2010

- Invisible air curtain maintains temperature
- Adjustable tilt shelves with built-in product stops for easy display set-up
- Included night blind reduces energy consumption during off-peak periods
- Temperature range: 0 to +10°C

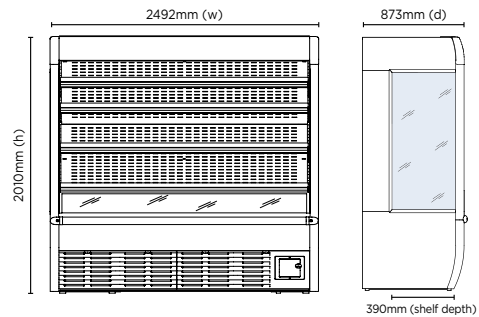

VISION2400



Vision ECO 2555L LED Open Display

Part No.	Capacity	Weight
3335277	2555L	443kg

External (mm)	
Width	2492
Depth	873
Height	2010

- Invisible air curtain maintains temperature
- Adjustable tilt shelves with built-in product stops for easy display set-up
- Included night blind reduces energy consumption during off-peak periods
- Temperature range: 0 to +10°C

Open Displays

Specification Reference Guide

Model	VISION1200	VISION1800	VISION2400
Part Number	3335274	3335276	3335277
Ext. Width (mm)	1322	1902	2492
Ext. Depth (mm)	873	873	873
Ext. Height (mm)	2010	2010	2010
Capacity	1330L	1913L	2555L
Temp. Range	0 to +10°C	0 to +10°C	0 to +10°C
Max. Ambient Temp.	25°C	25°C	25°C
Rated Power	2300W	2650W	3500W
Current	9.6A	13.6A	16.5A
Gross Weight	266kg	310kg	443kg
Refrigerant	R507A	R507A	R507A
Plugs Supplied	1	1	1
Power Supply	10A	15A	20A
Features			
Display Light Box	✓	✓	✓
Main Light	LED	LED	LED
Air Curtain	✓	✓	✓
Analogue Temp. Controller	✓	✓	✓
Feet/Castors	✓	✓	✓
No. of Shelves Incl. Base	5	5	5
Shelf Stops Incl.	✓	✓	✓
Night Blind	✓	✓	✓
Colour	White	White	White
Warranty			
Parts (Years)	1	1	1
Labour (Years)	1	1	1